

# INSTALLATION INSTRUCTIONS

## B100BTPA

Fender Mounting Instructions for MIN100, MIN150, MIN1600, MIN161200, MIN1900, MIN2200, MIN2218, MIN2260, MIN2280 and MIN9950 Fenders

### STEP 1

- A. Unpack all cartons and layout parts.
- B. Compare your parts with the hardware kit B100BTPA as shown in Figure 1.

B100BTPA Mounting Kit



Figure 1

### STEP 2

- A. Measure the travel of your suspension system. This measurement is used to determine the distance between the fender and the wheel. For air suspension systems let the air out of the air bags. For spring systems measure from the stops on the springs to the bottom of the frame.

**NOTE:** For air suspensions with travel exceeding 6". In some cases a travel stop may need to be installed, to prevent such large gaps between fenders & tires. This will help with alignment and 5<sup>th</sup> wheel plate clearance. (Questions regarding this issue, please call Spray Control @ 800-248-3855)

- B. Gap the fenders  $\frac{3}{4}$ " over the maximum travel point of your suspension system. The goal is to make sure the fender does not rub on the tire. Be sure to compensate for tire wear. You may need more than  $\frac{3}{4}$ " if you have worn tires.

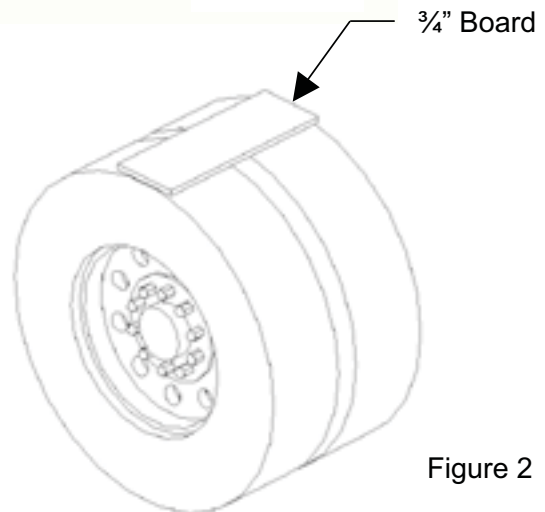

Figure 2

TESTED and TORTURED

**Minimizer**

# INSTALLATION INSTRUCTIONS

**TIP:** To establish the  $\frac{3}{4}$ " minimum gap needed in Step 2B for an air suspension system, place a  $\frac{3}{4}$ " board on top of tires after you have let out the air from your airbags, then place the fender on top of the board (see Figure 2). For a spring suspension system add  $\frac{3}{4}$ " to the measurement from step 2A.

## STEP 3

- A. Position the fenders exactly where you want to mount them. Visually pick and mark the locations the brackets will bolt or weld to the frame (depending on mounting kit). Try to use existing holes in the frame to bolt through. You can remove any existing frame bolt and replace it with the supplied bolt in the bracket kit. It is common for the front bracket to align with the existing quarter fender holes and the rear bracket to align with the holes left from the mud flap hanger.



Figure 3

**NOTE:** Depending on the length of the truck frame and the placement of the mud flap hangers, the fender may tuck inside the mud flap hanger. Figure 3 shows a truck with flaps and fenders.

- B. Spacers are supplied to bring the steel swivel away from the frame in the event of any obstructions (see Figure 4).

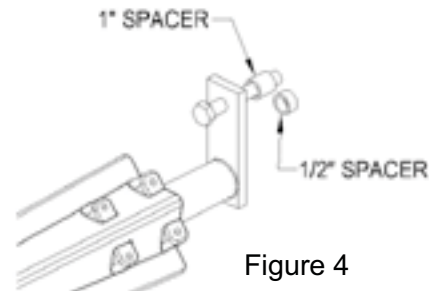
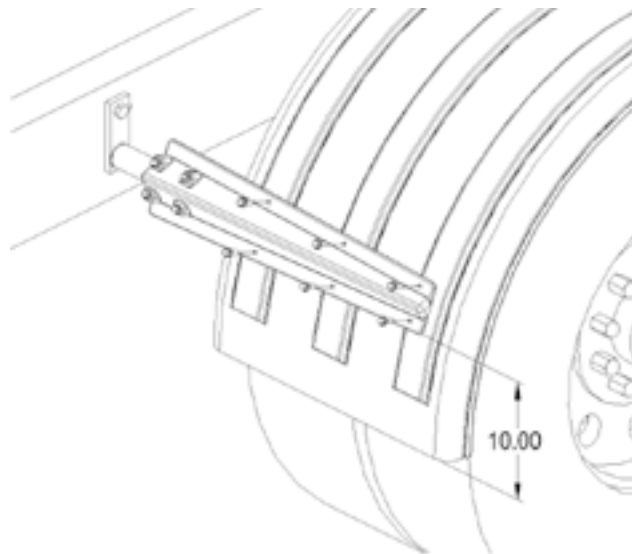

Figure 4

- C. Make sure the brackets are within 10" of the bottom of the fender to avoid wind blowing the fender back into the tire. If the front fender bracket is mounted higher than 10", run a piece of steel strapping on the inside of the fender to give it extra strength (see Figure 5 next pg).



TESTED and TORTURED



# INSTALLATION INSTRUCTIONS

## STEP 4

- A. Loosely clamp the bracket (part number PB501026A) and the backing block to the swivel (part number PB5015). Do not tighten down the bolts. Allow the bracket to rotate on the swivel during installation. See figure 6

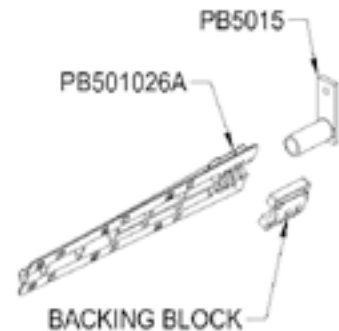

Figure 6

## STEP 5

- A. Once the brackets are placed in position with the fender, securely tighten down the 5/8" x 4-1/2" bolts that go through the PB5015 steel swivel attaching the swivel to the frame. See Figure 7

**TIP: HAND TIGHTEN WITH A WRENCH, THE BACKING BLOCK TO BRACKET PB501026A. DO NOT USE POWER TOOLS AS OVERTORQUING WILL CAUSE CRACKS IN THE BRACKET.**

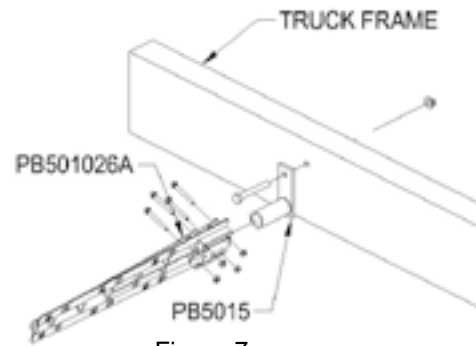

Figure 7

## STEP 6

- A. Drill six 5/16" holes thru fender using the holes in bracket PB501026A as a guide. Install the 5/16" x 1" bolts thru the bracket and into the fender. Use six 5/16" body washers and 5/16" nuts provided with kit on the inside of fender. Do not over tighten bolts as it may crack the bracket. Hand tightening of bolts is suggested. Make sure the fenders are square and aligned. Twists or bows in the fender will fatigue the material over time. See Figure 8.

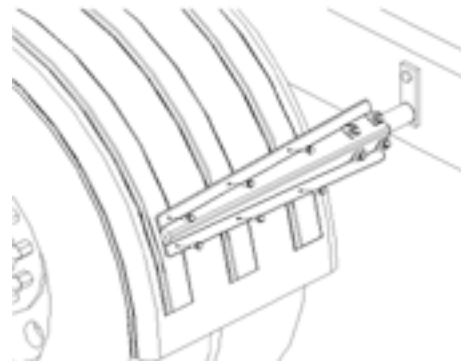

Figure 8

## STEP 7

- A. When the fender is level and positioned properly, tighten all bolts and nuts securely.

**NOTE: OCCASIONALLY CHECK THE 5/8" X 4-1/2" HEX BOLT ON THE FRAME TO MAKE SURE THEY DO NOT LOOSEN OVER TIME.**

TESTED and TORTURED

