

INSTALLATION INSTRUCTIONS

B4578BTSA

Fender Mounting Instructions for MIN400, MIN500, MIN700, MIN800 & MIN1500 Fenders

STEP 1

- A. Unpack all cartons and layout parts.
- B. Compare your parts with the hardware kit B4578BTSA as shown in Figure 1.

B4578BTSA Mounting Kit



Figure 1

STEP 2 (M500 and M700, 3 piece fenders)

- A. Lay the fenders out and clamp them together so that you can drill and bolt fenders together prior to installing them.
- B. Drill holes in fender from the bottom using the pre-existing holes as a guide. Use a $17/64$ " drill bit.
- C. Using the $1/4$ " x $3/4$ " long Phillips truss head bolts, attach the fender sections together. Tighten down the bolts using the supplied lock nuts. **DO NOT OVERTIGHTEN** the bolts. Start from the center and work towards the outside. See Figure 2.

Note:
M700 Shown

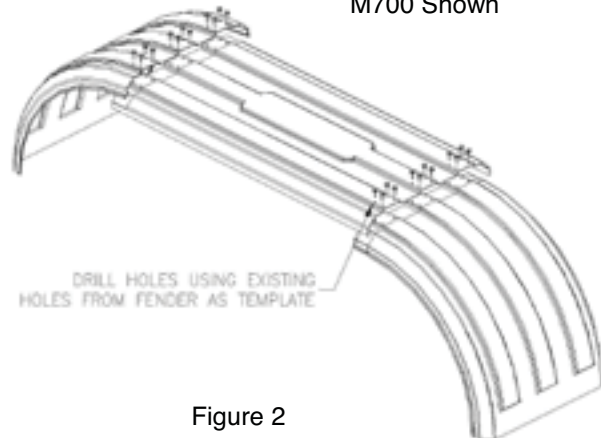

Figure 2

TESTED and TORTURED



INSTALLATION INSTRUCTIONS

STEP 2 (M400 and M800, 2 piece fenders)

- A. Lay the fender out and clamp together so that the ends butt together.
- B. Try to use the center bracket to attach the two fenders together using the 5/16" x 1-1/4" supplied bolts. If the center bracket does not line up correctly you can bolt the two pieces together and place the center bracket as close to the center of fenders as possible. Figure 3 shows a typical center bracket installation. Try and use existing holes to mount center bracket to truck frame.

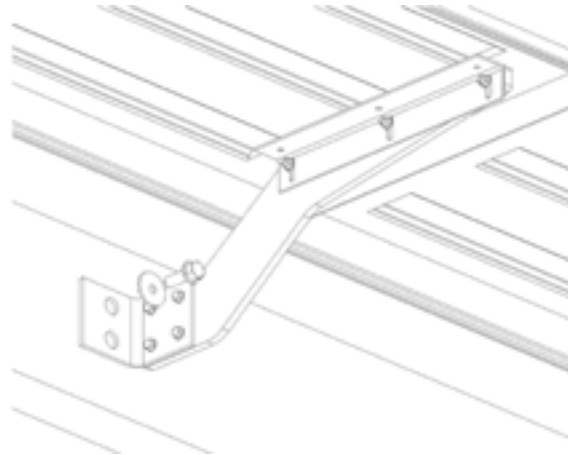

Figure 3

NOTE: The two holes in the steel mounting bracket are used for height adjustment. Only one hole is used for mounting. Pick one hole for mounting the center bracket and make sure the large dock washer goes on the outside of the angle bracket. The washer helps prevent the bracket from cracking due to road vibration

STEP 3

- A. Measure the travel of your suspension system. This measurement is used to determine the distance between the fender and the wheel. For air suspension systems let the air out of the air bags. For spring systems measure from the stops on the springs to the bottom of the frame. **NOTE:** For air suspensions with travel exceeding 6+". In some cases a travel stop may need to be installed, to prevent such large gaps between fenders & tires. This will help with alignment and 5th wheel plate clearance. (Questions regarding this issue, please call Spray Control @ 800-248-3855)

- B. Gap the fenders 3/4" over the maximum travel point of your suspension system. The goal is to make sure the fender does not rub on the tire. Be sure to compensate for tire wear. You may need more than 3/4" if you have worn tires.

TIP: To establish the 3/4" minimum gap needed in Step 2B for an air suspension system, place a 3/4" board on top of tires after you have let out the air from your airbags, then place the

Copyright SCS1 10/05/05

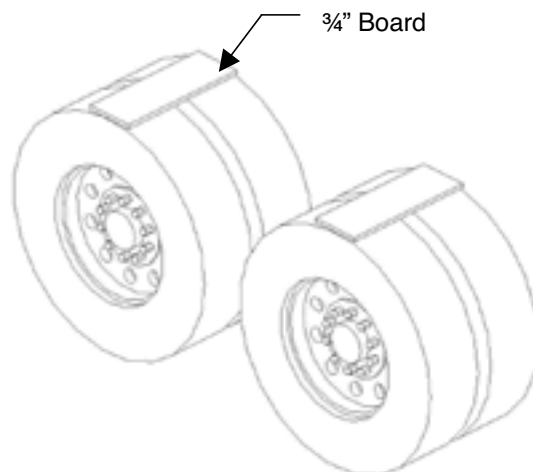

Figure 4

TESTED and TORTURED



INSTALLATION INSTRUCTIONS

fender on top of the board (see Figure 4). For a spring suspension system add $\frac{3}{4}$ " to the measurement from step 3A.

STEP 4

- A. Position the fenders exactly where you want to mount them. Visually pick and mark the locations the brackets will bolt to the frame. Try to use existing holes in the frame to bolt through. You can remove any existing frame bolt and replace it with the supplied bolt in the bracket kit. It is common for the front bracket to align with the existing quarter fender holes and the rear bracket to align with the holes left from the mud flap hanger.

NOTE: Depending on the length of the truck frame and the placement of the mud flap hangers, the fender may tuck inside the mud flap hanger. Figure 5 shows a truck with flaps and fenders.

- B. Spacers are supplied to bring the steel swivel away from the frame in the event of any obstructions (see Figure 6).
- C. Make sure the brackets are within 10" of the bottom of the fender to avoid wind blowing the fender back into the tire. If the front fender bracket is mounted higher than 10", run a piece of steel strapping on the inside of the fender to give it extra strength (see Figure 7).



Figure 5

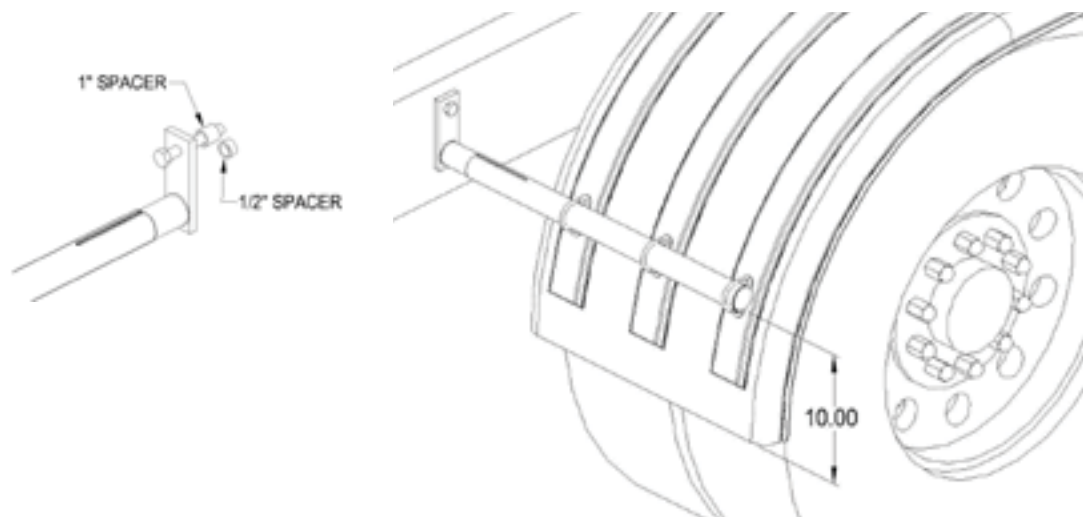

Figure 7

TESTED and TORTURED

Minimizer

INSTALLATION INSTRUCTIONS

STEP 5

- A. Push on the mounting tube (part number PB5050) to the swivel (part number PB5015). See Figure 8. PB5060 is already assembled to tube.

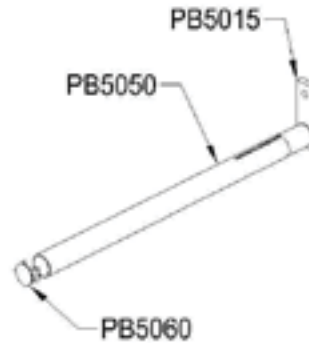

Figure 8

STEP 6

- A. Drill six 5/16" holes thru fender using the holes in fender washers as a guide. Install the 5/16" x 2" x 3.5" U-bolts thru the bracket and into the fender. Use two fender washers per u-bolt. Place one on the inside and outside of fender. Use 3 U-bolts per fender bracket tube. Do not over tighten U-bolts. Hand tightening of bolts is suggested. Make sure the fenders are square and aligned. Twists or bows in the fender will fatigue the material over time. See figure 9.

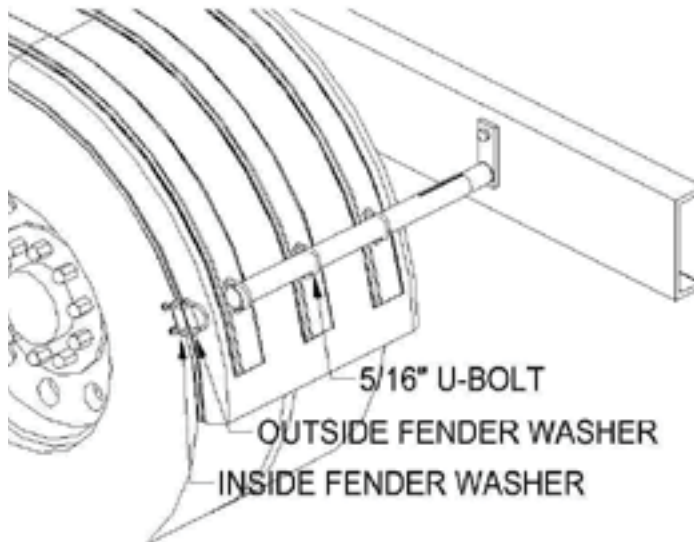

Figure 9

TESTED and TORTURED



INSTALLATION INSTRUCTIONS

NOTE:

Figure 10 shows a finished installation for a stainless mounting kit.



Figure 10

STEP 7

A. When the fender is level and positioned properly, tighten all bolts and nuts securely.

NOTE: OCCASIONALLY CHECK THE 5/8" X 4-1/2" HEX BOLT ON THE FRAME TO MAKE SURE THEY DO NOT LOOSEN OVER TIME.

TESTED and TORTURED

