

INSTALLATION INSTRUCTIONS

B9900WOA

Fender Mounting Instructions for MIN9900 or MIN1300 Fenders

STEP 1

- A. Unpack all cartons and layout parts.
- B. Compare your parts with the hardware kit B9900WOA as shown in Figure 1.

B9900WOA Mounting Kit



Figure 1

STEP 2

- A. Lay the fenders out and clamp them together. (for MIN9900 series overlap the front fender over the back fender)(for MIN1300 series butt up the ends and bolt them together)

NOTE: On the MIN9900 series fenders the fender with the recessed section goes on the rear of the tandem. See Figure 2.

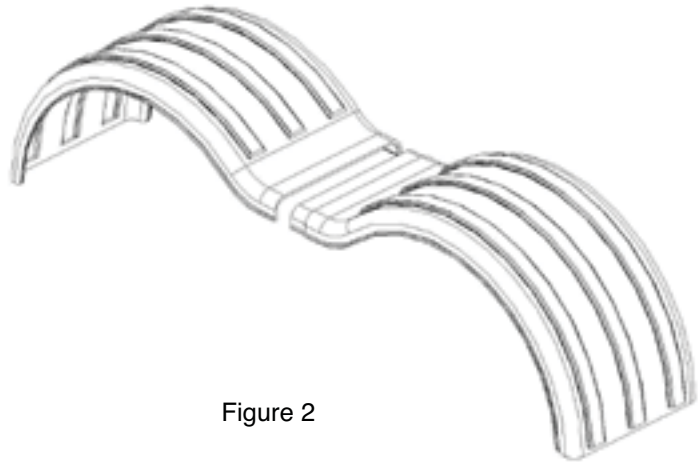

Figure 2

TESTED and TORTURED



INSTALLATION INSTRUCTIONS

STEP 3

- A. Measure the travel of your suspension system. This measurement is used to determine the distance between the fender and the wheel. For air suspension systems let the air out of the air bags. For spring systems measure from the stops on the springs to the bottom of the frame. **NOTE:** For air suspensions with travel exceeding 6+”. In some cases a travel stop may need to be installed, to prevent such large gaps between fenders & tires. This will help with alignment and 5th wheel plate clearance. (*Questions regarding this issue, please call Spray Control @ 800-248-3855*)

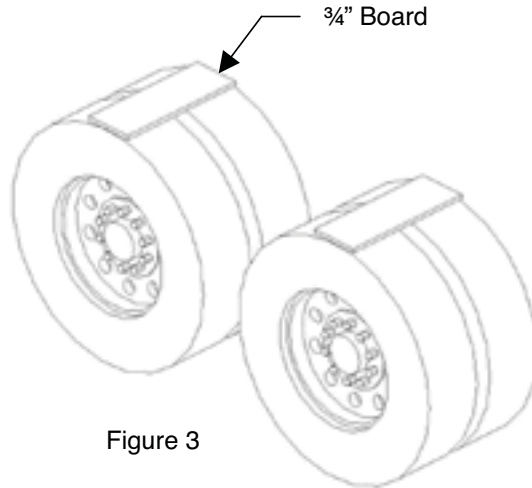

Figure 3

- B. Gap the fenders $\frac{3}{4}$ ” over the maximum travel point of your suspension system. The goal is to make sure the fender does not rub on the tire. Be sure to compensate for tire wear. You may need more than $\frac{3}{4}$ ” if you have worn tires.

TIP: To establish the $\frac{3}{4}$ ” minimum gap needed in Step 2B for an air suspension system, place a $\frac{3}{4}$ ” board on top of tires after you have let out the air from your airbags, then place the fender on top of the board (see Figure 3). For a spring suspension system add $\frac{3}{4}$ ” to the measurement from step 3A.

STEP 4

- A. Position the fenders exactly where you want to mount them. Visually pick and mark the locations the brackets will weld to the frame.

NOTE: Depending on the length of the truck frame and the placement of the mud flap hangers, the fender may tuck inside the mud flap hanger. Figure 4 shows a truck with flaps and fenders.



Figure 4

Copyright SCSi 10/05/05

Page 2

TESTED and TORTURED



INSTALLATION INSTRUCTIONS

- B. Weld fender bracket to frame. You can bolt a plate (not supplied) to the frame and weld to that plate or just weld the brackets right to the frame if preferred. **Check your owners' manual before welding directly to the frame. Most manufactures suggest that you do not weld anything directly to the frame.** Make sure the brackets are aligned to the fender prior to welding. Plate should be a minimum of ¼" thick steel. See Figure 5.

* SCSi does not suggest you weld directly to the frame. Check with your manufacturer before welding directly to the frame.

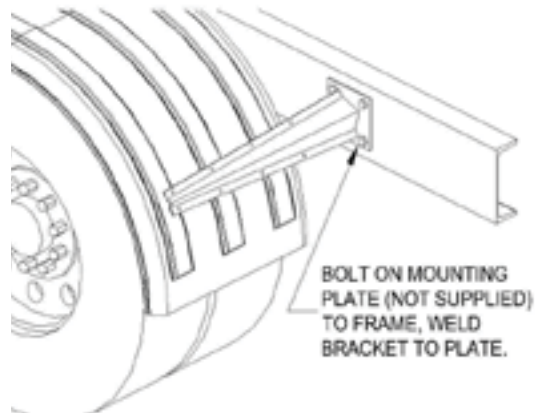

Figure 5

- C. Before welding bracket or bolting mounting plate, make sure the brackets are within 10" of the bottom of the fender to avoid wind blowing the fender back into the tire. If the front fender bracket is mounted higher than 10", run a piece of steel strapping on the inside of the fender to give it extra strength (see Figure 6). When brackets are in position, weld bracket or bolt mounting plate to frame.

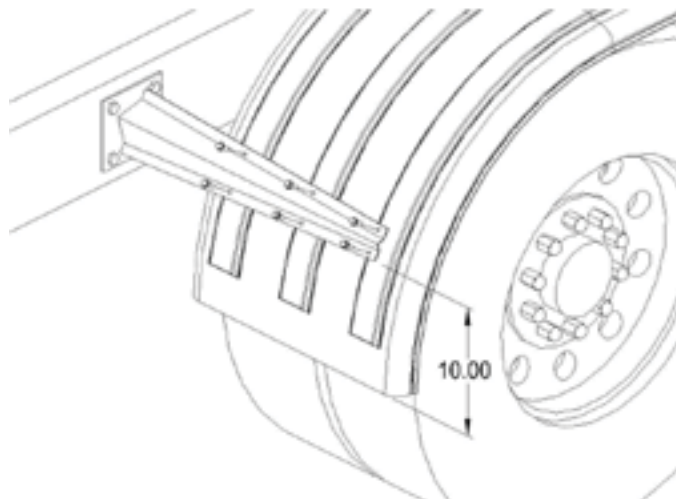

Figure 6

TESTED and TORTURED

Minimizer

INSTALLATION INSTRUCTIONS

- D. Mount the center bracket anywhere in-between the tandem. The center bracket will lay on the flat piece between the fenders. The center bracket will hold the two fenders together. See Figure 7.

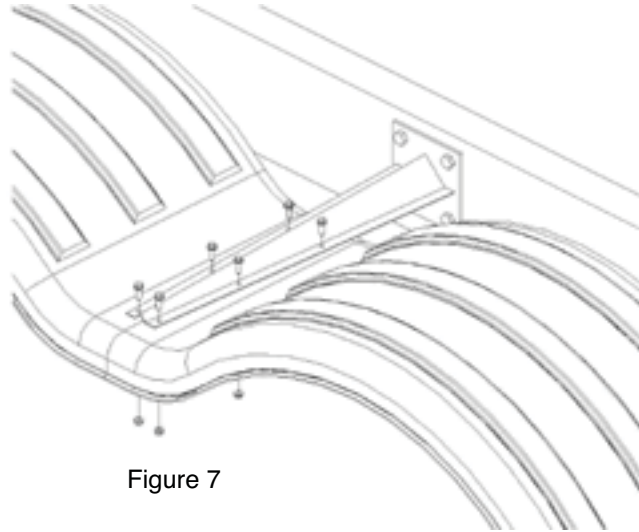

Figure 7

STEP 5

- A. Drill six 5/16" holes thru fender using the holes in bracket PB5010 as a guide. Install the 5/16" x 1" bolts thru the bracket and into the fender. Use six 5/16" body washers and 5/16" nuts provided with kit on the inside of fender. Hand tightening of bolts is suggested. Make sure the fenders are square and aligned. Twists or bows in the fender will fatigue the material over time. See Figure 8.

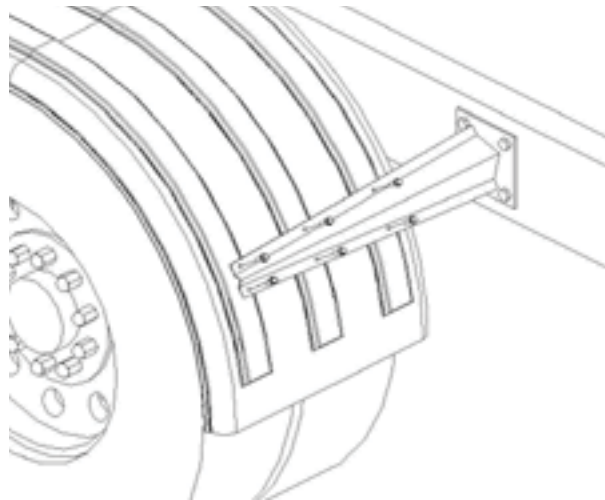

Figure 8

STEP 6

- A. When the fender is level and positioned properly, tighten all bolts and nuts securely.

TESTED and TORTURED

