



Installation Instructions for Minimizer Steerable Lift Axle Fender Bracket Kit #104264

Bracket Kit is Compatible with Watson Chalin SL20K-2065 Axle Equipped With Bolt on Brake Cam Tube

DESIGNED FOR USE WITH MIN2220 FENDERS

SL20K-2065

Tru-Track 20K

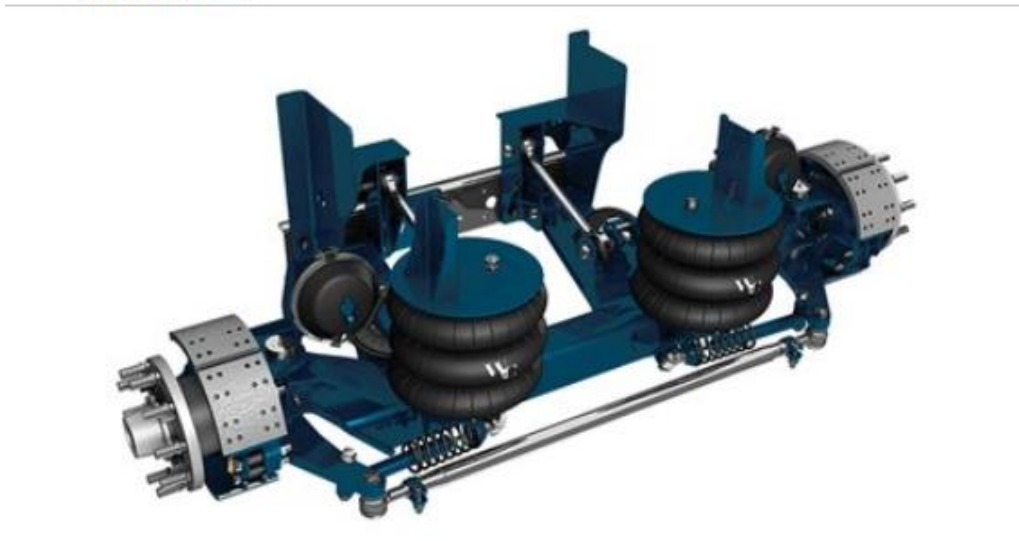

1

¹ Picture Source: <https://www.watsonsusensions.com/Truck/Steerable-Lift-Axles/20K-Capacity-Steer/SL20K-2065>

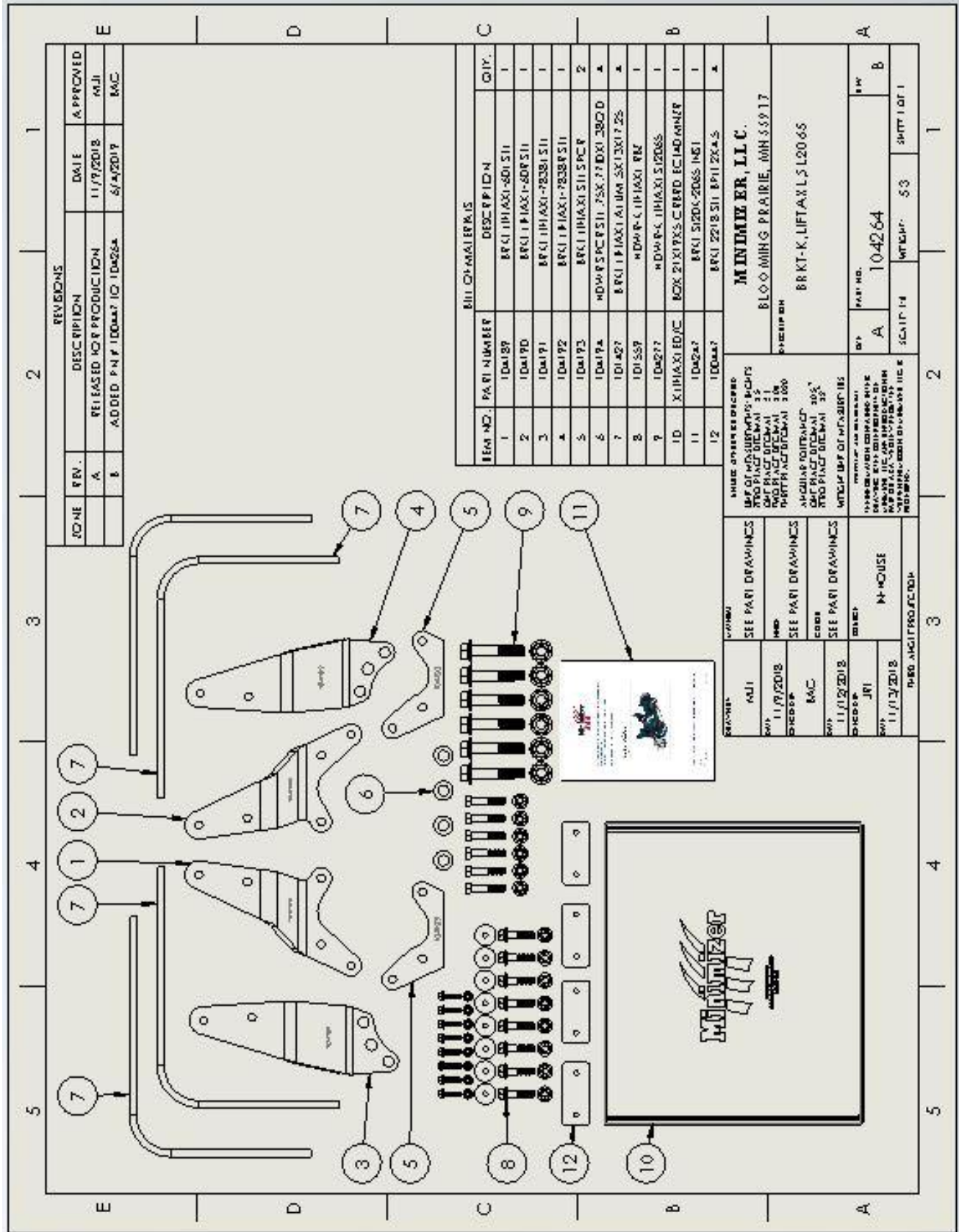

Fender Installation Steps

1. Remove the wheel assembly from the hub on the left side of the vehicle.
2. Remove the brake drum from the hub.
3. Remove the metal dust shield (if equipped) that is attached to the inside of the spindle backbone assembly as shown in Figure 1.



Figure 1 - View of Dust Shield

4. Remove the brake return springs and brake shoes.
5. Drain the oil bath and remove the wheel hub and bearings from the spindle to gain access to mounting bolts as shown in Figure 2 below.



Figure 2 - Spindle with Wheel Hub Removed.

- At the front corner of the axle fit the offset mounting plate (104193) and fender bracket (104189) around the brake cam tube as shown in Figure 3 and Figure 4 below. Use the $\frac{1}{2}$ "-13 hex bolts and flange nuts provided in the kit and torque them to 117 ft-lbs.

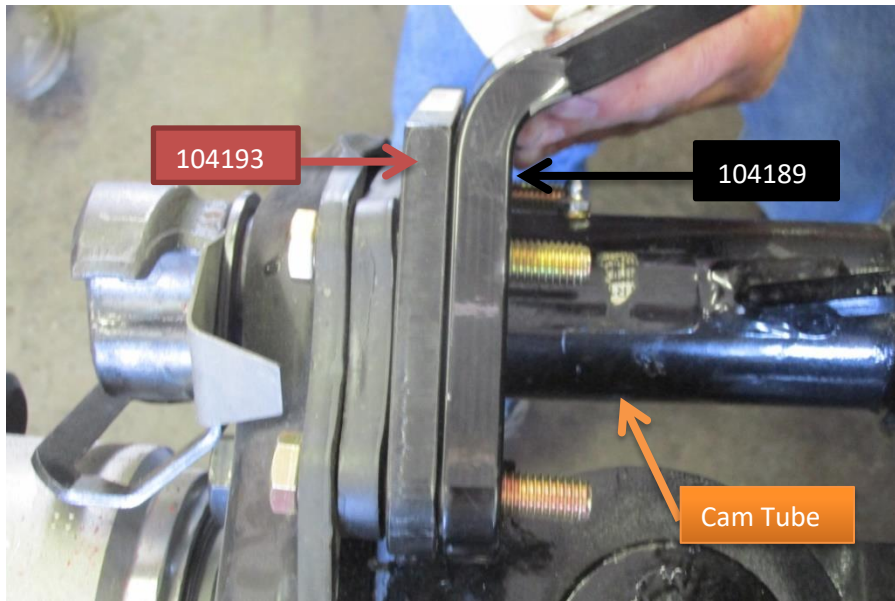

Figure 3 - Installing 104193 & 104189

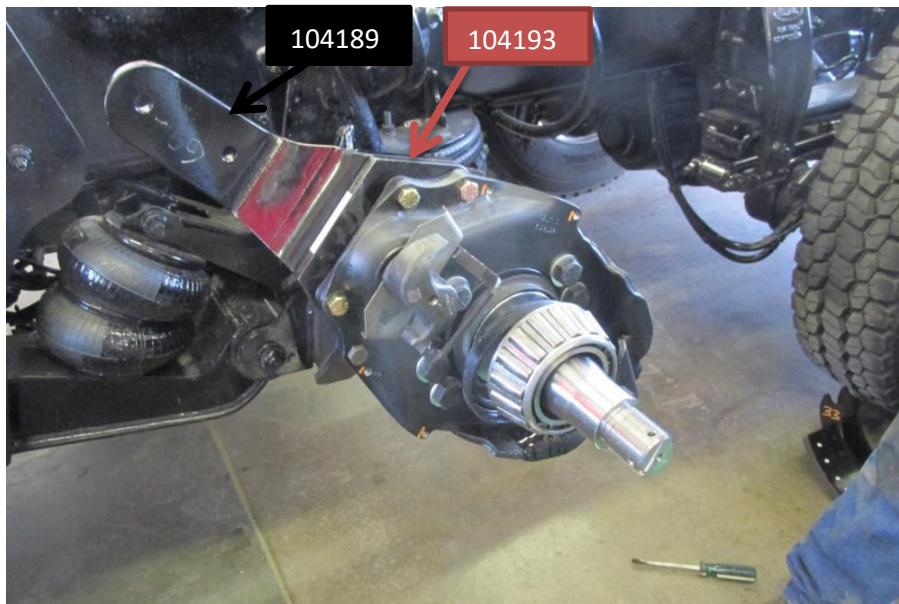

Figure 4 - View of 104189 after installation

7. Remove the lower three backing plate to spindle bolts on the rear side of the spindle as shown in Figure 5 below.



Figure 5 - Spindle Bolt Locations

8. Install the rear bracket (104191) using the spacers (104194) between the bracket and the spindle on the two bottom holes as shown in Figure 6 and Figure 7 below. The upper hole does not require a spacer. Use the $\frac{3}{4}$ -16" bolts and locknuts that are provided in the kit. Torque the $\frac{3}{4}$ " hardware to 315 ft.-lbs.

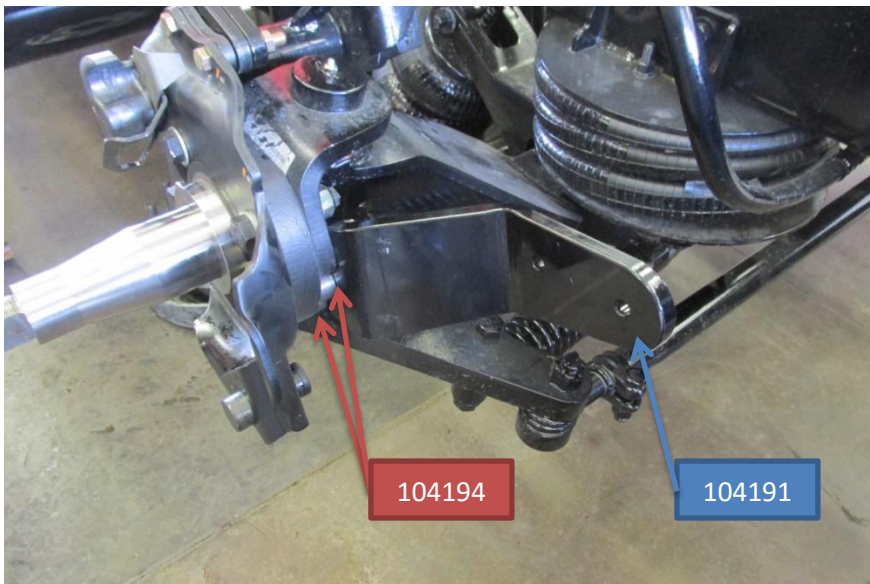

Figure 6 - Bracket and Spacer Installation

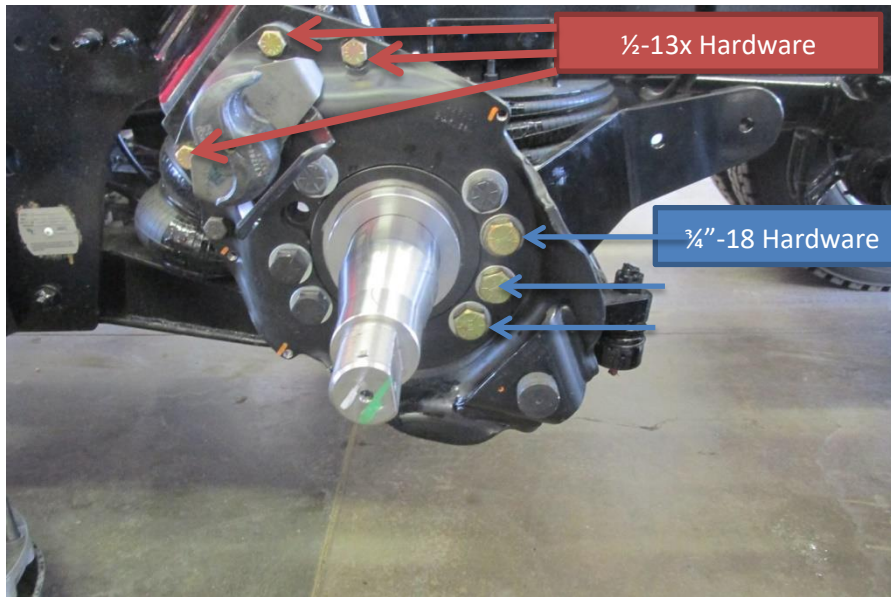

Figure 7 - View of Bolts & Brackets Installed

9. Re-install the wheel hub, brake shoes, brake drum, and wheel assembly. Make sure to torque all wheel lugs, and wheel hub hardware according to the axle manufacturer's specifications.
10. Verify that there is at least 1" of clearance between the steel bracket and the tire. For most applications with 445/25 R22.5 or 445/65 R22.5 tires clearance should be approximately 2". See Figure 8 for further detail.



Figure 8 – Check Clearance between Tire and Bracket

11. Clamp aluminum arms to the axle bracket per the steps listed below:

- a. **Align the bottom edge of the aluminum arm 101427 flush with the bottom edge of 104189**
 - b. Place a 1 ½" thick wood block in between the aluminum arm and the tire to establish proper clearance for the tire.
 - c. Clamp the front aluminum arm 101427 to the surface of the steel bracket 104189 closest to the truck frame with a vice grip clamp.
 - d. Make sure the clamp is tight enough to hold the wood block between the arm and the tire.
 - e. **Align the top edge of the aluminum arm 101427 flush with the top edge of bracket 104191.**
 - f. Place a ¾" thick wood block in between the aluminum arm and the tire to establish proper clearance for the tire.
 - g. Clamp the rear aluminum arm 101427 to the surface of the steel bracket 104191 closest to the truck frame with a vice grip clamp.
12. Place a 1.5" block on top of the tire to establish clearance between the tire and top of the fender as shown in Figure 9.



Figure 9 - Aluminum arms and wood blocks clamped in position

13. Place the Minimizer fender over the tire and aluminum arms so it rests on the wood block as shown in Figure 10.
- a. Measure the distance from the floor to the bottom edge of the fender on both ends and adjust the position of the fender until both distances are equal.
 - b. The aluminum arms may need to be adjusted inward or outward so they make even contact with the fender.
 - c. For axle applications with 425/65 R22.5 or 445/65 R22.5 tires there should be at least 1.5"-2" of clearance between the fender and the tire.

- i. The bottom edge of the front aluminum arm will typically align 10.5"-11.5" above the bottom edge of the fender
- ii. The bottom edge of the rear aluminum arm will typically align 1.5"-2.5" above the bottom edge of the fender



Figure 10 –Views of Fender Installed over Tire and Brackets

14. Use the holes in the steel brackets attached to the axle as a template to locate and mark the mounting holes in the aluminum arms, see Figure 11.

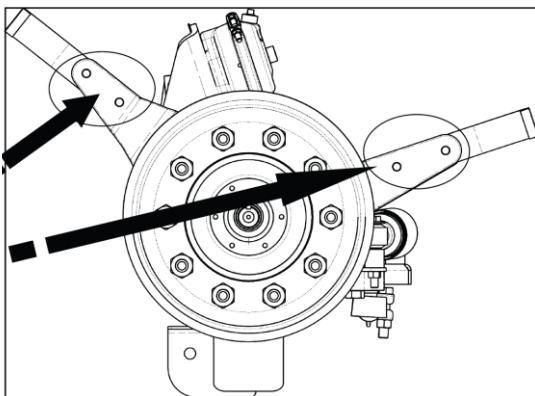

Figure 11 -Mark Mounting Hole Locations

15. Drill two 9/16" holes in each aluminum arm in the locations that were marked in step 14.
16. If necessary, measure and trim any excess material from the aluminum arms that extends past the bend in the mounting plate.
17. Bolt the aluminum arms to the steel fender brackets using the 1/2" x 2" flange head bolts and the 1/2" top lock flange nuts as shown in Figure 12.

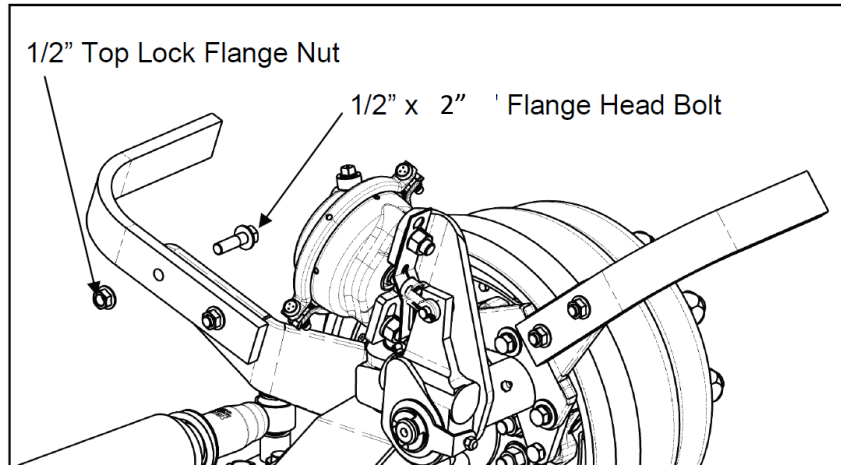

Figure 12 - Fasten aluminum arms

18. Attach the fender to the aluminum arms and backing plates as shown in Figure 13.
 - a. **In order to be eligible for Minimizer warranty, the steel backing plates 100447 must be installed on the exterior surface of the fender.**

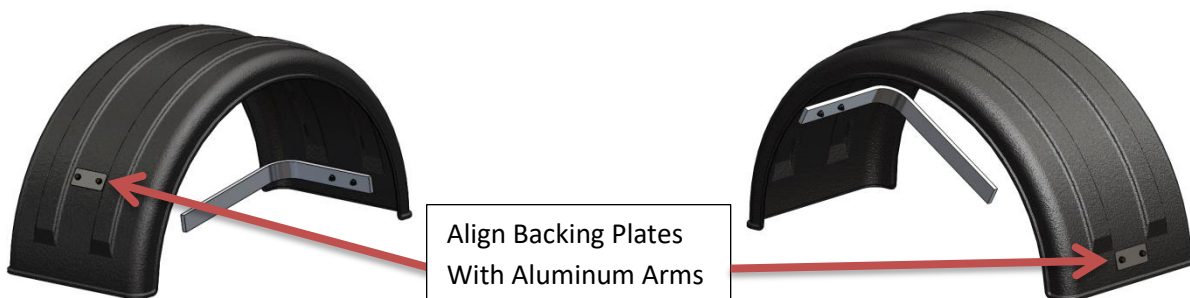

Figure 13 - Backing Plate Installation Detail

- b. Confirm that the fender is parallel to the tire.
 - c. Align the backing plate 100447 so it is even (top to bottom) with the aluminum arm. Use one plate for each aluminum arm.
 - d. Drill clearance holes or tap threads in the aluminum arms.
 - i. Option 1) Drill two 11/32" diameter holes thru the fender to the arm using the steel plate as a template. Use 5/16-18 bolts w/self-locking nuts (provided in kit).
 - ii. Option 2) Drill and tap 5/16"-18 threads into the aluminum arm. This option provides increased tire clearance. Shorter 5/16"-18 bolts (not included) will be required for this option
 - e. **Tighten the 5/16-18 hardware to a recommended torque of 5-7 ft.-lbs. Do not exceed the recommended torque.**
19. Repeat steps 1 thru 18 to install the brackets and fenders on the right side of the vehicle.