

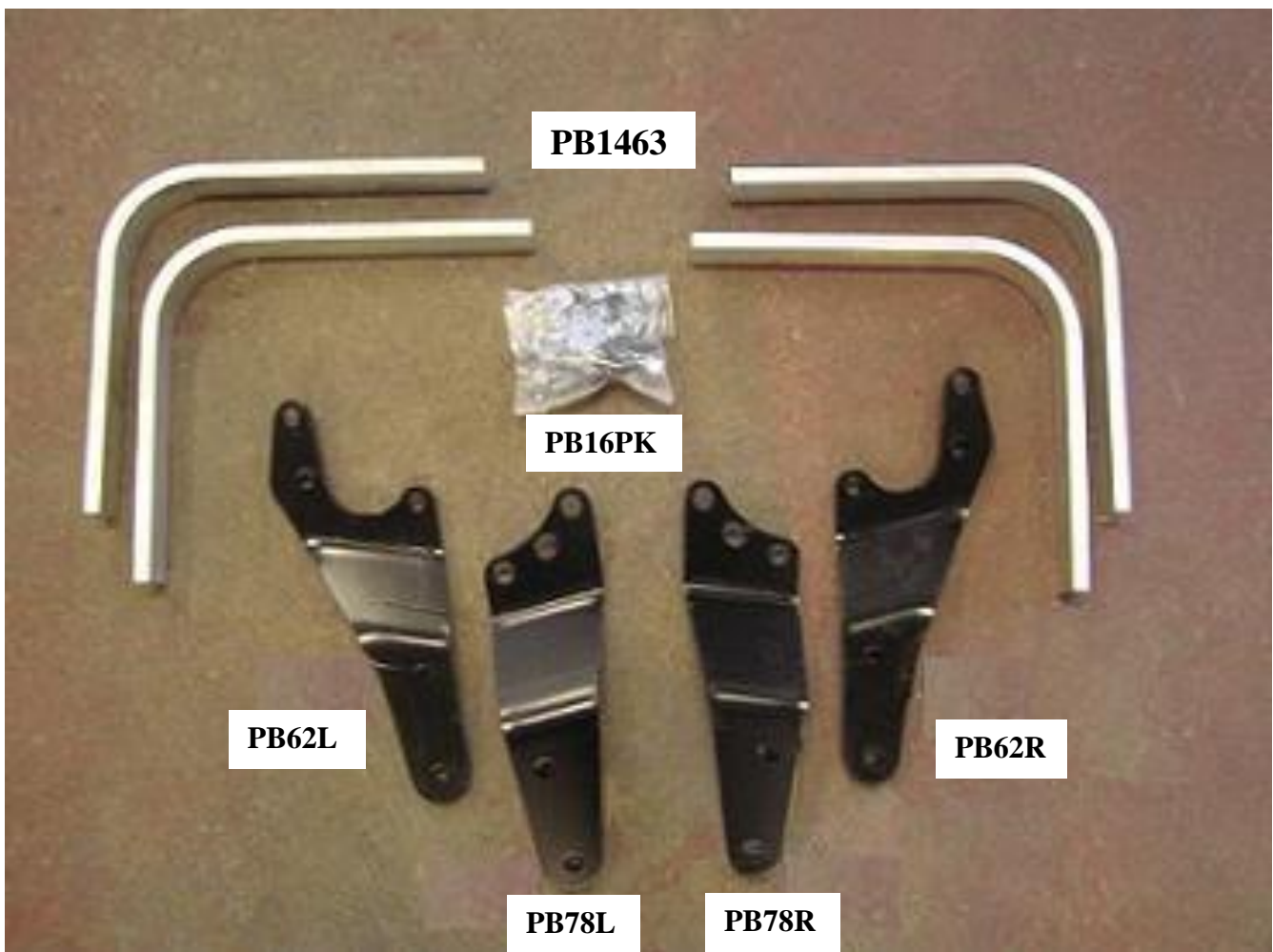

**INSTALLATION INSTRUCTIONS
STEERABLE AXLE BRACKET KIT
FOR MERITOR REAR CAM
KIT #:B865SBA**



****BOLTS ARE ONLY PROVIDED FOR STEPS 8 & 9. BOLT SIZES VARY IN STEPS 1-7 DEPENDING ON THE APPLICATION AND ARE NOT PROVIDED.**

1. Remove the hub and drum assembly (with outboard hubs, you may only have to remove the drum).
2. Remove the lower three backing plate to spindle bolts on the rear/back of the spindle.



3. Install the bracket part# PB78L/R with longer grade 8 bolts and 2 to 7, SAE flat washers between the spindle and the offset mounting plate. (This is to get the plate away from the irregular surface). Remove the top front and the lower two 1/2" bolts on the cam tube flanges and install the PB62L on the left side and the PB62R on the right side. Replace the 6 each 1/2" bolts with 1/2" longer grade 8 bolts.
4. Re-install the brake drum.
5. Install tire and wheel.
6. Cut the aluminum arms to length (some might be a little long depending on the application.)
7. Hold the aluminum arms in place leaving about a 1-1/2" gap between the fender and the tire.
8. Clamp the aluminum arms in place with a vise grip. (Make sure the inside of the arms point directly to the center of the spindle.) Mark and drill 1/2" holes in the aluminum arms. Bolt the aluminum arms to steel mounting brackets using 1/2" bolts with self-locking nuts.
9. Install the fender on top of the aluminum arms. Roll fender until it is approximately the same distance from end of the fender to the 2" arm on both ends of the fender. Make sure fender is parallel to tire. Drill 2 each 5/16" diameter holes on 6" centers (approximately 3" left and right of center) to bolt the fender to the arm. Use 5/16" bolts w/self-locking nuts (provided in kit).

Recommended Placement of Brackets and Fenders for Correct Installation

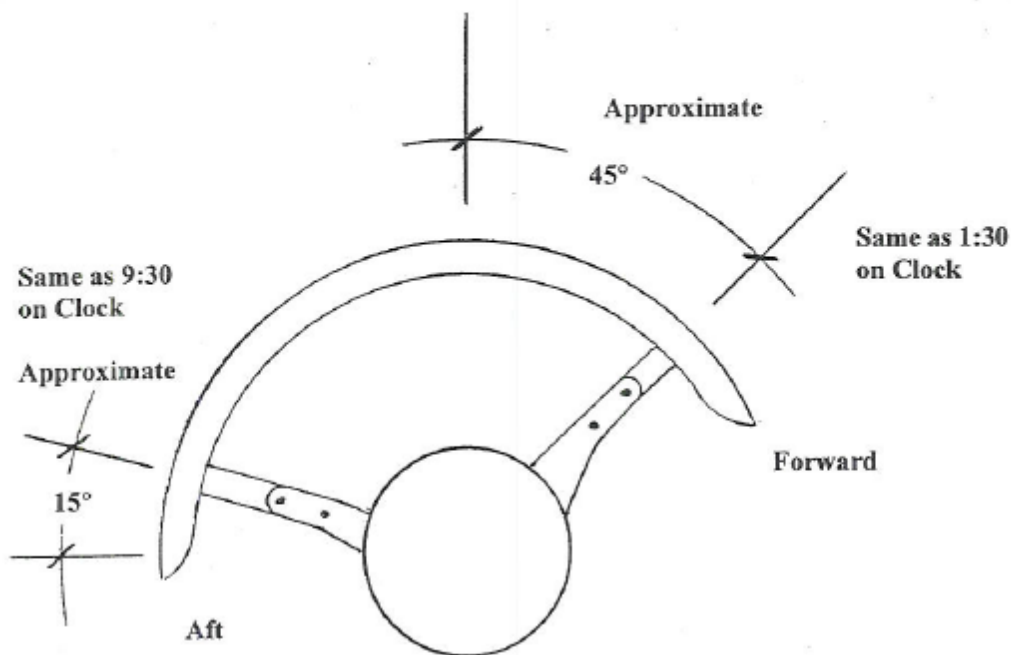

Instructions for use of MIN221800 fenders with Minimizer steerable lift axle brackets:

- Inside the Minimizer bracket kit locate four steel plates (Minimizer part number 100447)
- The steel plates are to be installed on the exterior surface of the fender.
 - Align the steel plate so it is even (top to bottom) with the aluminum arm. Use one plate for each aluminum arm.
 - Drill two 21/64" holes through the fender using the steel plate as a template
 - Drill two 21/64" holes in the aluminum arm using the fender and steel plate as a template.
 - Use the 5/16-18"x 1-1/4" hardware provided by Minimizer to fasten the fender in between the aluminum arm and the steel plate.
 - **Tighten the 5/16-18X1-1/4 bolts to a recommended torque of 5-7 ft-lbs. Do not exceed the recommended torque.**
- Failure to install the exterior steel plates at the time of installation will void the manufacturer's warranty on the MIN221800 fender component.
- If installing fender model MIN161200 or any model other than MIN221800, the steel plates are not necessary and may be discarded.

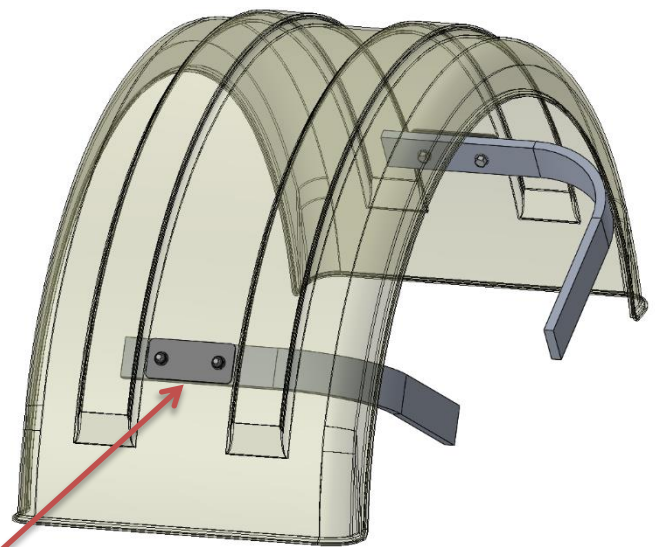
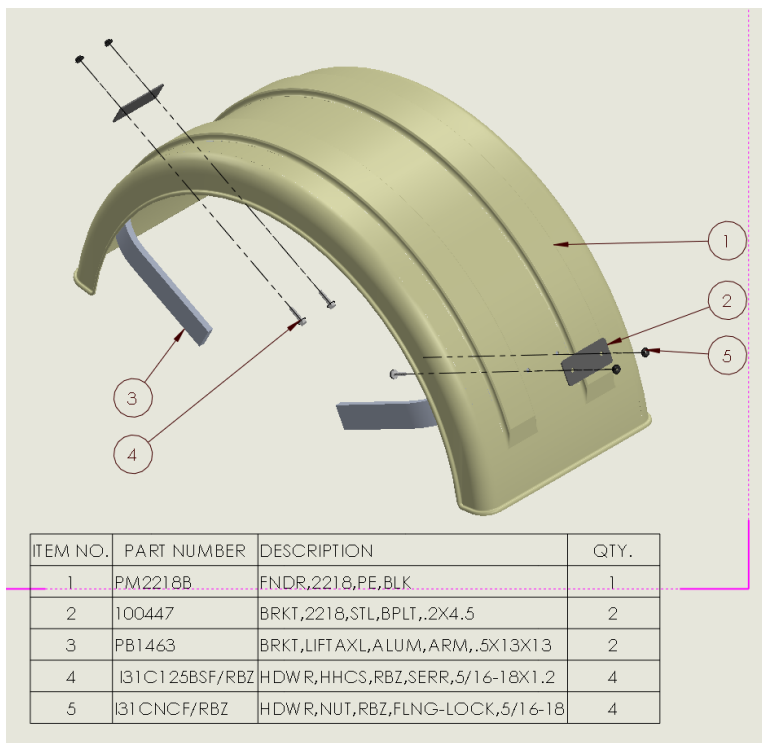

ALIGN STEEL PLATE WITH ALUM ARM

