

Installation Instructions for Fender Bracket Kit 10001331



Document #10004977, Revision A

Brackets are Compatible with Models:

MIN100, MIN150, MIN2200, MIN2260 & MIN2480.

WARNING: DO NOT APPLY CHROME POLISH, METAL POLISH, OR ANY TYPE OF BUFFER TO MINIMIZER SILVER MIRROR PRODUCTS. USING ANY OF THE ABOVE ITEMS WILL VOID THE PRODUCT WARRANTY.

- Wash brackets with mild soap and water.
- Do not wipe the mirror finish when it is dry or with a dry cloth. Only use a clean, damp microfiber cloth when wiping or drying your Minimizer Silver Mirror products.
- Do not use any abrasive cleaners or pads.
- To maintain the luster of Minimizer Silver Mirror products, apply an off the shelf wax/polish combination that you would use on the painted surface of your automobile. Follow the manufacturer's instructions on the product of your choice e.g., "Meguiars", "Mothers Gold", "Blue Coral".

STEP 1 - IDENTIFY PARTS

- A. Lay out parts and hardware packs.
- B. Compare the parts and hardware with bracket kit 10001331 as shown in **Figure 1**.

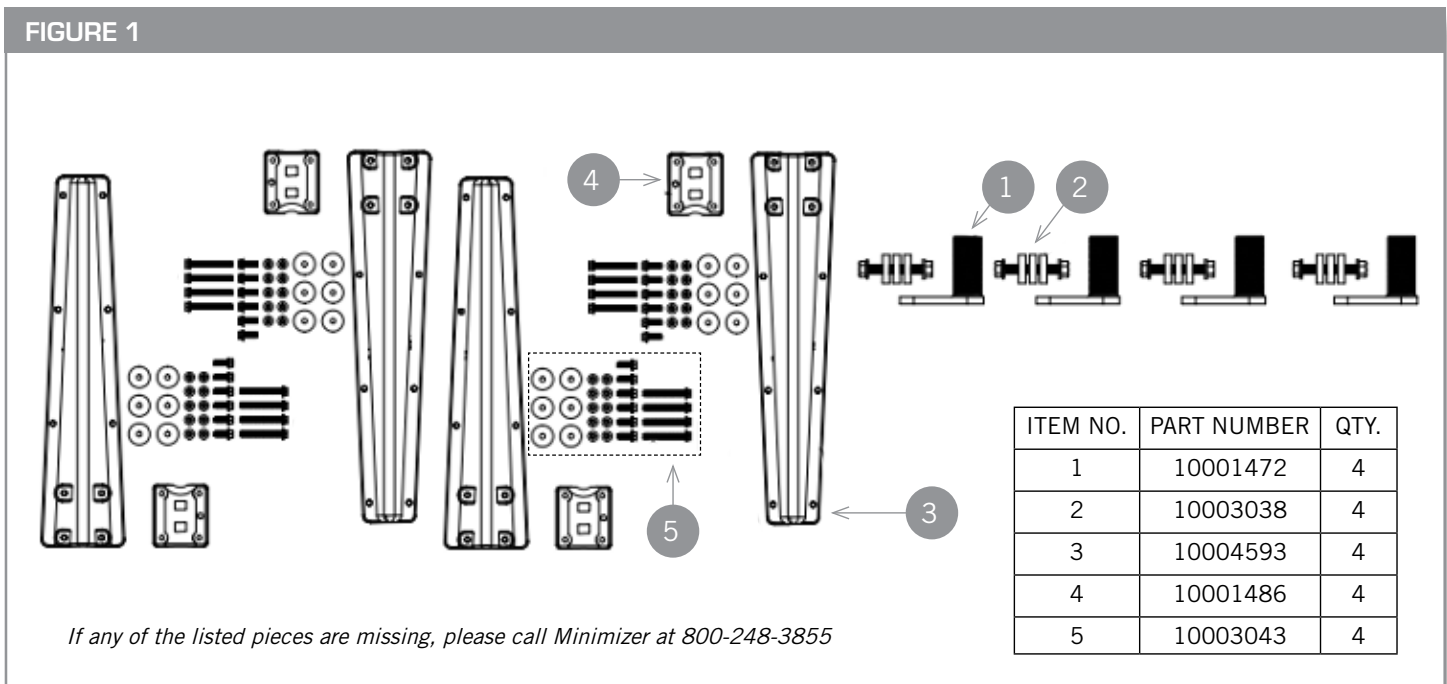

STEP 2 - DETERMINE SIZE OF SPACERS AND POSITION FENDERS

- A. Confirm the total suspension travel distance. This is used to determine the clearance required between the fender and tire.
 - a. For air suspension systems, dump the air bags and confirm it is the lowest point of travel.
 - i. Understand that some air suspension designs may cause the wheels to roll closer to the fender (roll forward) as the suspension deflates. In order to make sure the fenders are centered on the tires, test the suspension in the inflated and deflated positions to determine the best positioning so that the fenders are centered over the tires in the inflated position.
 - ii. For air suspensions with travel exceeding 6", a travel stop may need to be installed to reduce required clearance between the fenders and tires. This will also improve alignment and 5th wheel plate clearance. (Please call Minimizer @ 800-248-3855 for questions regarding this issue).
 - b. For spring systems, measure the distance between the spring assembly and the bump stop on the frame and record the measurement.

Installation Instructions for Fender Bracket Kit 10001331

Document #10004977, Revision A

Brackets are Compatible with Models:

MIN100, MIN150, MIN2200, MIN2260 & MIN2480.



- B. Place the fenders on spacer blocks above the tires.
- In most applications 1.5" of tire clearance is best. The goal is to ensure the fender does not rub the tire.
 - The minimum clearance recommended is $\frac{3}{4}$ " above the maximum travel point of the suspension system.
 - For an air suspension system, place a $\frac{3}{4}$ " to 1.5" thick board on top of the tires after the air is released from the airbags. **(See Figure 2)**
 - For spring suspensions use spacer material that is $\frac{3}{4}$ " to 1.5" thicker than the measurement recorded above.
- C. For trucks with air suspension, raise and lower the suspension to confirm the clearance between the fenders and wheels and that the fenders will be centered front to rear when the air suspension is inflated.

FIGURE 2

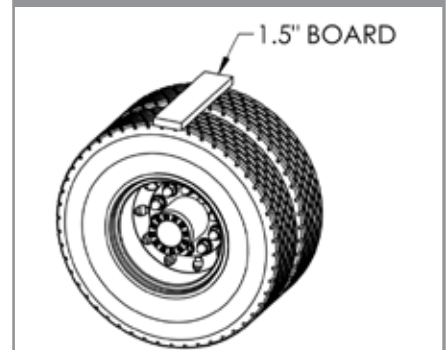
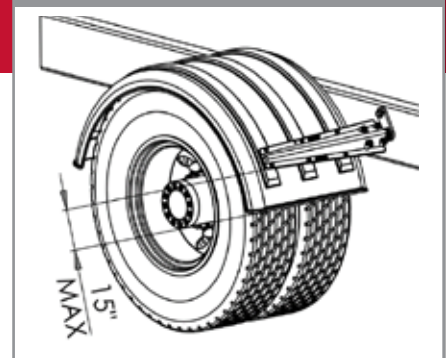

FIGURE 3



STEP 3 - POSITION BRACKETS AND REVIEW MUDFLAP CONFIGURATION

- With the fenders in position, mark and test fit the brackets where they will attach to the frame.
- If possible, use existing bolt holes in the frame to attach.

Tip: It is common for the front bracket to align with the existing quarter fender holes and the rear bracket to align with the holes left from the mud flap hanger.

- If possible, position the mounting brackets low on the fender so they are no more than 15" from the bottom. **(See Figure 3)**
 - Brackets mounted 8-12" from the edge is optimal.
 - The goal is to reduce the risk of the leading edge of the fender from blowing back against the tire during high wind.

Tip: If the front fender bracket is mounted higher than 15", refer to the link below for further suggestions on adding additional support
<http://www.minimizer.com/instructions.html>

FIGURE 4

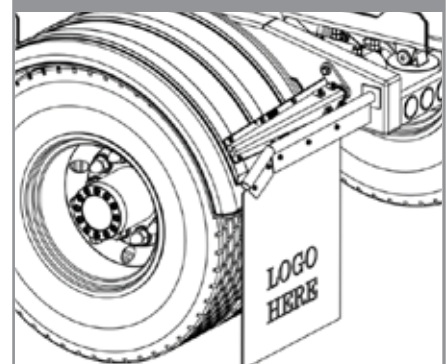

NOTES:

- In some applications the rear fender will tuck inside the mud flap hanger as shown in **Figure 4**. This is the recommended configuration.
- Minimizer recommends using a separate hanger to hold the mudflap that is independent from the fender assembly.
- If a mudflap attached to a lighted fender is backed over, the fender and mounting brackets may be damaged.
- If there is no other option but to attach mudflaps to the fender, best practice is to cut vertical slots in the mudflap (in line with the mounting holes) to allow it to break away from the fender.

Warning: Attaching a mudflap to the bottom of a lighted fender as shown in **Figure 5** will void manufacturer's warranty.

FIGURE 5 - NOT RECOMMENDED

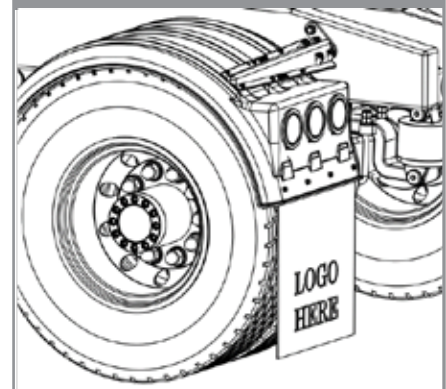

Installation Instructions for Fender Bracket Kit 10001331



Document #10004977, Revision A

Brackets are Compatible with Models:

MIN100, MIN150, MIN2200, MIN2260 & MIN2480.

- Round spacers are supplied to hold the (10001472) swivel bracket away from the frame when needed. In some cases, frame components may interfere with the required bracket location and require a spacer. (See Figure 6)
- **USE SPACERS ONLY WHEN NECESSARY!** The ideal installation is to mount the (10001472) swivel bracket directly to the frame using no spacers.
- If using the mounting hole inside the pipe of the swivel bracket, the excess flat steel may be trimmed off to provide a cleaner look.

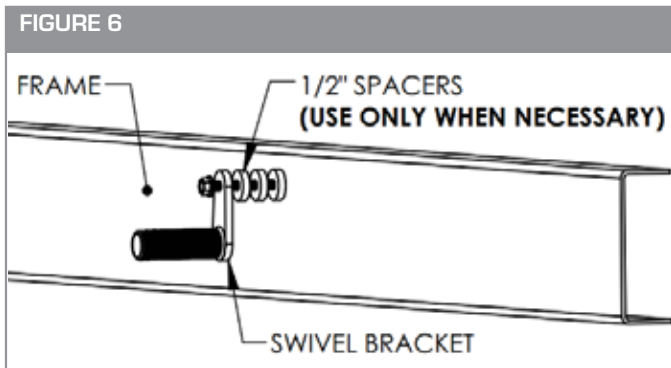

FIGURE 7

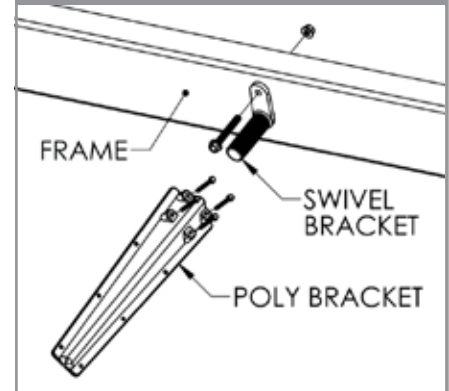
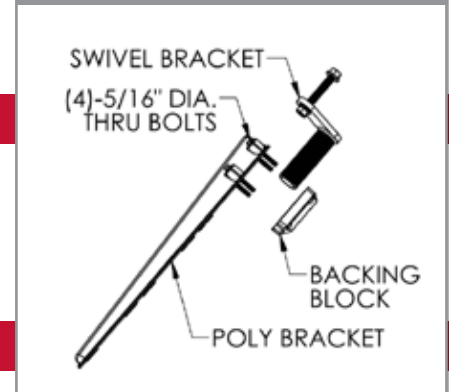

FIGURE 8



STEP 4 - ATTACH BRACKETS TO TRUCK FRAME

- A. Once the brackets are in position with the fender, tighten the 5/8" x 4-1/2" bolt that goes through the (10001472) swivel bracket to attach the swivel securely to the frame. (See Figure 7)
 - a. **Recommended torque is 160-170 ft-lbs.**

STEP 5 - ASSEMBLE BRACKETS

- A. Place four 5/16" x 3" bolts through the (10004593) poly bracket and the (10001486) backing block to clamp the (10001472) swivel. (See Figure 8)
 - a. **Make sure the pipe of the (10001472) is fully inserted in the poly parts.**
- B. Install the nuts finger tight and align the bracket to the fender.
- C. Tighten the four bolts evenly as described below.
 - a. Do not completely tighten one corner of the backing block before moving to the next corner. Tighten each nut 30%-50% and move to the next nut following the pattern shown in Figure 9.
 - b. Repeat the tightening pattern 2-3 times until backing block is flush against the (10004593) poly bracket.
 - c. **Recommended torque is 10-15 ft-lbs.**
 - i. ALWAYS SPIN THE NUT AND HOLD THE HEAD STATIONARY.
 - ii. DO NOT EXCEED RECOMMENDED TORQUE OR EMBED THE BOLT HEAD IN THE BRACKET. THIS WILL VOID MANUFACTURERS WARRANTY.

FIGURE 9

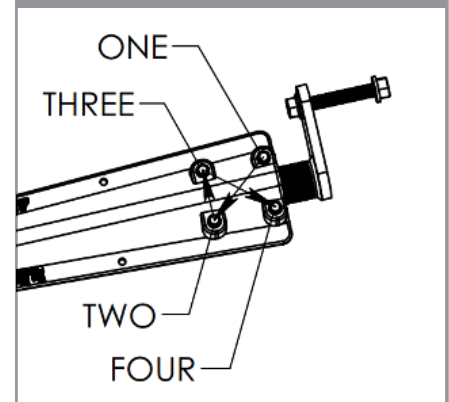

For further details, refer to the link below

<https://www.youtube.com/watch?v=IB4apbSEckI&t=15s>

Installation Instructions for Fender Bracket Kit 10001331



Document #10004977, Revision A

Brackets are Compatible with Models:

MIN100, MIN150, MIN2200, MIN2260 & MIN2480.

STEP 6 - ATTACH FENDER TO BRACKETS

- A. Attach the Fender to the (10004593) poly bracket.
 - a. Verify that the fenders are level across the frame and aligned with the tires for optimal clearance. Fenders that are installed in a deformed or twisted state may lead to material fatigue and reduce the life of the fender.
 - b. Drill six 5/16" holes through the fender using the holes in the (10004593) poly bracket as a guide.
 - c. Install the 5/16" x 1" bolts through the bracket and into the fender. **(See Figure 10)**
 - d. Use six 5/16" fender washers and 5/16" nuts provided with the kit on the underside of the fender.
 - e. **Recommended torque is 10-15 FT-LBS.**
DO NOT EXCEED RECOMMENDED TORQUE
For further details, refer to the link in step 5.

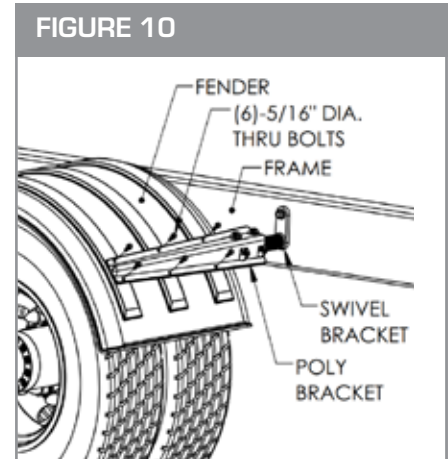

STEP 7 - INSPECT AND REPEAT FOR ALL FENDERS

- A. For trucks with air suspension, raise and lower the suspension one final time to confirm that there is adequate clearance between the fenders and wheels.
- B. Repeat the install process for all fenders.
- C. Once fenders are in service, occasionally inspect the 5/8" bolts in the frame to confirm they do not loosen over time.

A DIVISION OF HIGH BAR BRANDS, LLC



2701 18th Street SW, Owatonna, MN 55060
1-800-248-3855 | Fax: 507-583-7540
www.highbarbrands.com