

Installation Instructions for Fender Bracket Kit 10001346

Document #10004991, Revision A
Brackets are Compatible with Models: MIN200



STEP 1 - IDENTIFY PARTS

- Lay out parts and hardware packs.
- Compare the parts and hardware with bracket kit 10001346 as shown in **Figure 1**.

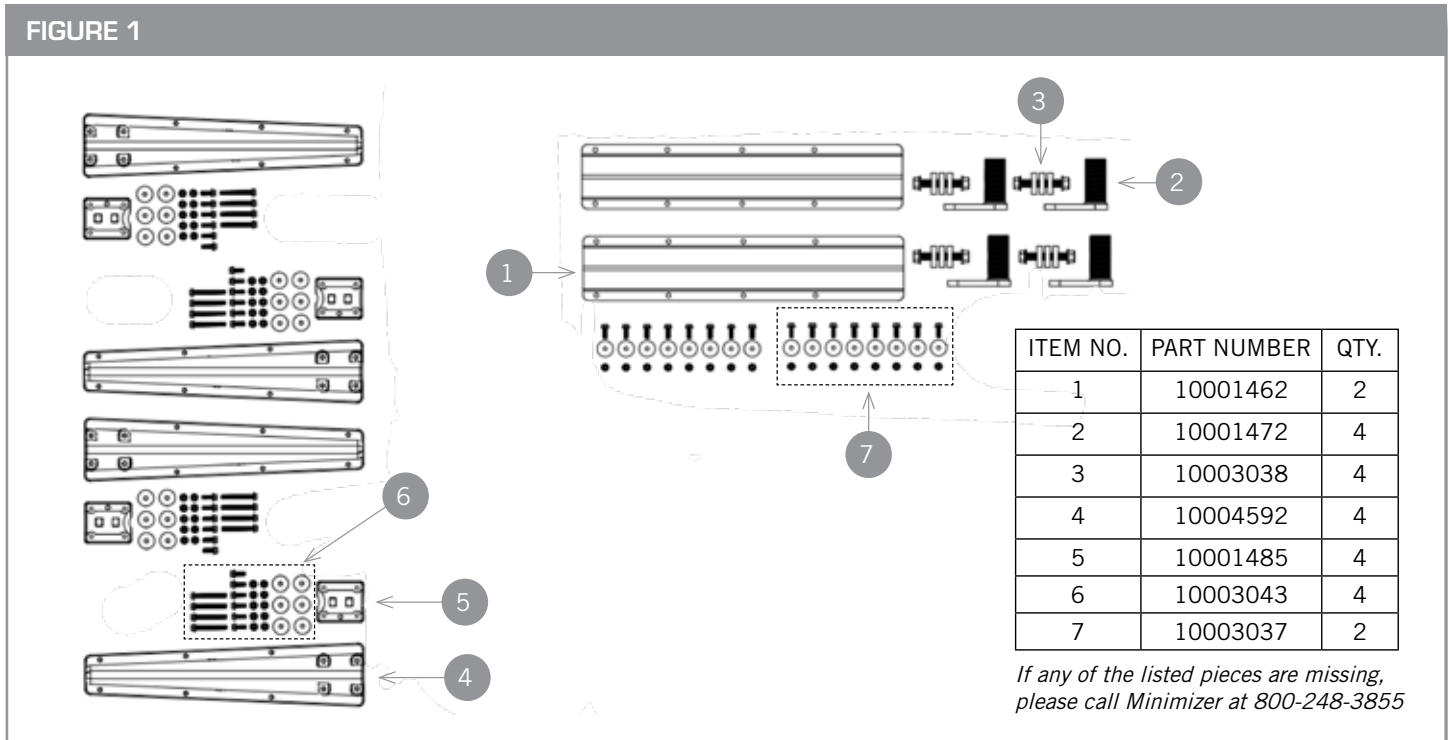

STEP 2 - JOIN FENDERS

- Lay the fenders out and clamp them together once they are aligned. This will make bolting them together easier. **(See Figure 2)**
- The vertical lip of both fenders needs to be cut off to accommodate the (10001462) center support bracket.
 - This will be located on the side that is closest to the truck frame.
 - Place a mark 3" in from the end of each fender. **(See Figure 3)**

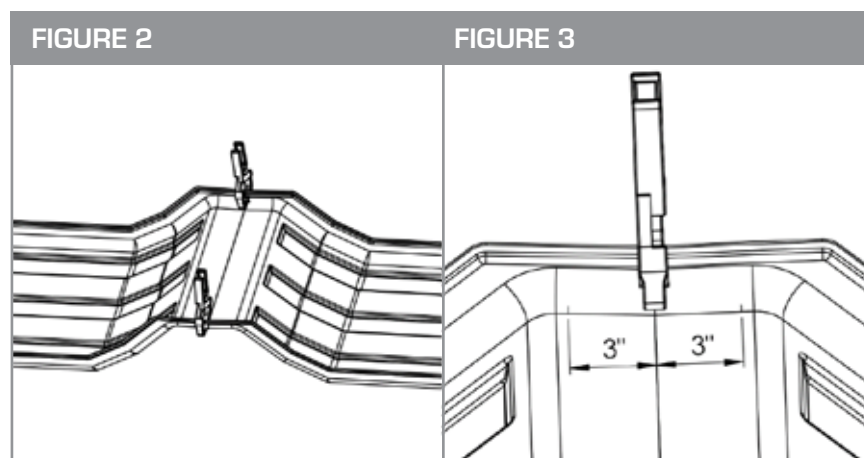

Installation Instructions for Fender Bracket Kit 10001346

Document #10004991, Revision A

Brackets are Compatible with Models: MIN200



- c. Draw outline of the area that needs to be cut out similar to **Figure 4**.
- d. Cut out the marked off area.
- C. Make sure the center bracket and the trim plate (if purchased) are centered between the two fenders. (See **Figure 5**)

Tip: The center bracket (10001462) "V" should be facing down.

- a. Drill eight holes through the fender and trim plate from the bottom using the holes in the (10001462) center bracket as a guide.
- b. Use eight 5/16" x 1" bolts to bolt the fenders, trim plate, and center bracket together.
- c. Use eight 5/16" nuts provided with the kit on the underside of the fenders.
- d. **Recommended torque is 10-15 ft.-lbs.**

Tip: Start with the bolts closest to the truck frame and work towards the outside.

STEP 3 - DETERMINE SIZE OF SPACERS AND POSITION FENDERS

- A. Confirm the total suspension travel distance. This is used to determine the clearance required between the fender and the tire.
 - a. For air suspension systems, dump the air bags and confirm it is the lowest point of travel.
 - i. Understand that some air suspension designs may cause the wheels to roll closer to the fender (roll forward) as the suspension deflates. In order to make sure the fenders are centered on the tires, test the suspension in the inflated and deflated positions to determine the best positioning so that the fenders are centered over the tires in the inflated position.
 - ii. For **air suspensions with travel exceeding 6"**, a travel stop may need to be installed to reduce required clearance between the fenders and tires. This will also improve alignment and 5th wheel plate clearance. (Please call Minimizer @ 800-248-3855 for questions regarding this issue).
 - b. For spring systems, measure the distance between the spring assembly and the bump stops on the frame and record the measurement.
- B. Place the fenders on spacer blocks above the tires.
 - a. In most applications 1.5" of tire clearance is best.
 - b. The goal is to ensure the fender does not rub the tire.
 - i. The minimum clearance recommended is $\frac{3}{4}$ " above the maximum travel point of the suspension system.
 - c. For an air suspension system, place a $\frac{3}{4}$ " to 1.5" thick board on top of the tires after the air is released from the airbags. (See **Figure 6**)
 - d. For spring suspensions use spacer material that is $\frac{3}{4}$ " to 1.5" thicker than the measurement recorded above.
- C. For trucks with air suspension, raise and lower the suspension to confirm the clearance between the fenders and wheels and that the fenders will be centered front to rear when the air suspension is inflated.

FIGURE 4

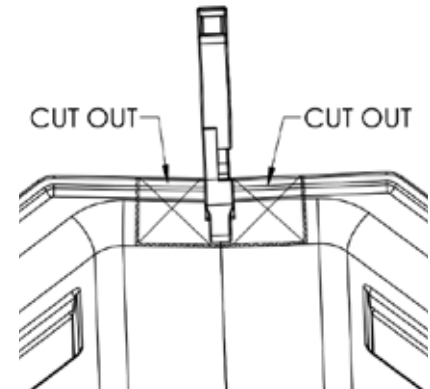

FIGURE 5

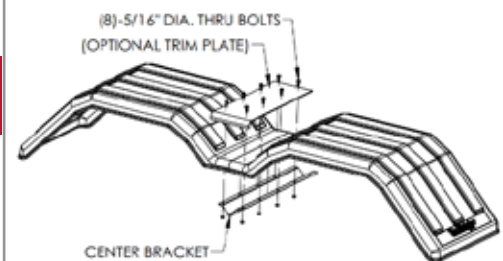
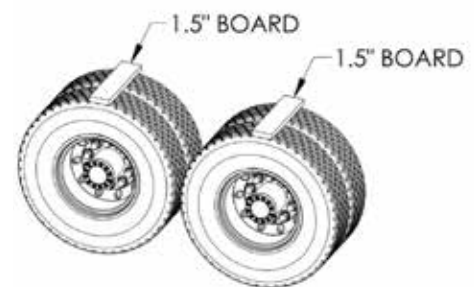

FIGURE 6



Installation Instructions for Fender Bracket Kit 10001346

Document #10004991, Revision A

Brackets are Compatible with Models: MIN200



STEP 4 - POSITION BRACKETS

- A. With the fenders in position, mark and test fit the brackets where they will attach to the frame.
- B. If possible, use existing bolt holes in the frame to attach the front and rear (10004592) poly brackets.

Tip: It is common for the front bracket to align with the existing quarter fender holes.

- C. If possible, use existing bolt holes in the frame to attach a steel plate (not supplied) for the center bracket and weld the bracket to the plate. **(See Figure 7)**
 - a. Plate should be a minimum of 1/4" thick.
- D. Another option is to weld the bracket directly to the frame

Warning: Review vehicle owner's manual before welding directly to the frame.

- E. If possible, position the mounting brackets low on the fender so they are no more than 15" from the bottom. **(See Figure 8)**
 - a. Brackets mounted 8-12" from the edge is optimal.
 - b. The goal is to reduce the risk of the leading edge of the fender from blowing back against the tire during high wind.

Tip: If the front fender bracket is mounted higher than 15", refer to the link below for further suggestions on adding additional support <http://www.minimizer.com/instructions.html>

NOTES:

- Round spacers are supplied to hold the (10001472) swivel bracket away from the frame when needed. In some cases, frame components may interfere with the required bracket location and require a spacer. **(See Figure 9)**
- **USE SPACERS ONLY WHEN NECESSARY!** The ideal installation is to mount the (10001472) swivel bracket directly to the frame using no spacers.
- If using the mounting hole inside the pipe of the swivel bracket, the excess flat steel may be trimmed off to provide a cleaner look.

STEP 5 - ATTACH BRACKETS TO TRUCK FRAME

- A. Once the front bracket is in position with the fender, tighten the 5/8" x 4-1/2" bolt that goes through the (10001472) swivel bracket to attach the swivel securely to the frame. **(See Figure 10)**
 - a. **Recommended torque is 160-170 ft-lbs.**

FIGURE 7

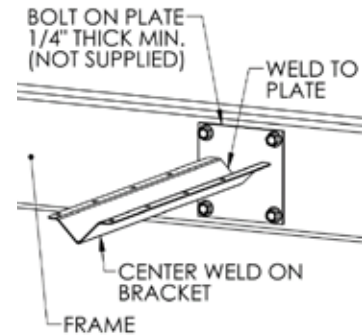

FIGURE 8

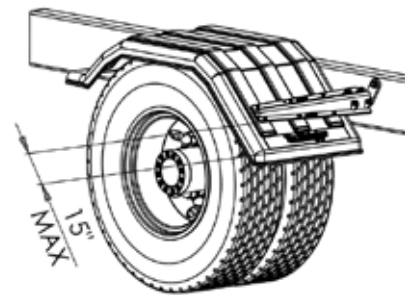

FIGURE 9

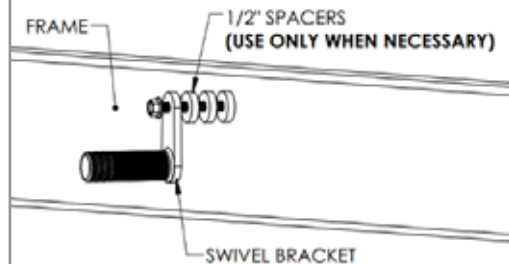
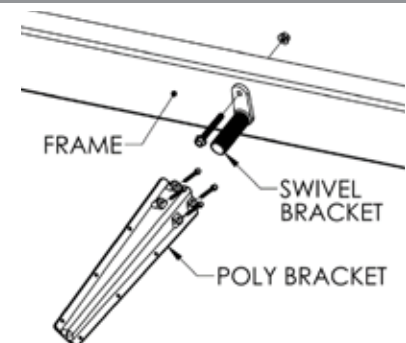

FIGURE 10



STEP 6 - ASSEMBLE BRACKETS

- A. Place four 5/16" x 3" bolts through the (10004592) poly bracket and the (10001485) backing block to clamp the (10001472) swivel.
(See Figure 11)
- a. **Make sure the pipe of the (10001472) is fully inserted in the poly parts.**
- B. Install the nuts finger tight and align the bracket to the fender.
- C. Tighten the four bolts evenly as described below.
- a. Do not completely tighten one corner of the backing block before moving to the next corner. Tighten each nut 30%-50% and move to the next nut following the pattern shown in **Figure 12**.
- b. Repeat the tightening pattern 2-3 times until backing block is flush against the (10004592) poly bracket.
- c. **Recommended torque is 10-15 ft-lbs.**
- i. ALWAYS SPIN THE NUT AND HOLD THE HEAD STATIONARY.
- ii. DO NOT EXCEED RECOMMENDED TORQUE OR EMBED THE BOLT HEAD IN THE BRACKET. THIS WILL VOID MANUFACTURERS WARRANTY.
- For further details, refer to the link below*
<https://www.youtube.com/watch?v=IB4apbSEckI&t=13s>

FIGURE 11

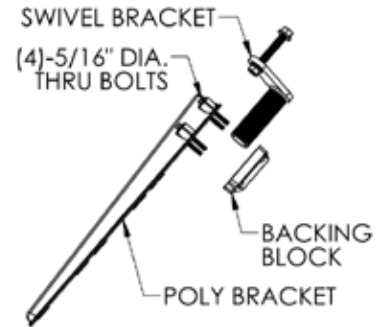

FIGURE 12

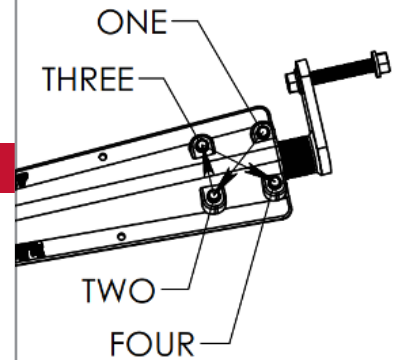
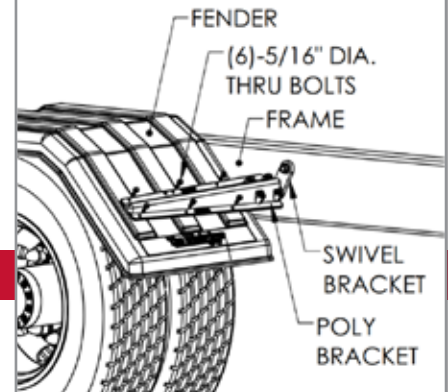

FIGURE 13



STEP 7 - ATTACH FENDER TO BRACKETS

- A. Attach the fender to the (10004592) poly bracket.
- a. Verify that the fenders are level across the frame and aligned with the tires for optimal clearance. Fenders that are installed in a deformed or twisted state may lead to material fatigue and reduce the life of the fender.
- b. Drill six 5/16" holes through the fender using the holes in the (10004592) poly bracket as a guide.
- c. Install the 5/16" x 1" bolts through the bracket and into the fender.
(See Figure 13)
- d. Use six 5/16" fender washers and 5/16" nuts provided with the kit on the underside of the fender.
- e. **Recommended torque is 10-15 FT-LBS.**
DO NOT EXCEED RECOMMENDED TORQUE
For further details, refer to the link in step 6 above.

STEP 8 - INSPECT AND REPEAT FOR ALL FENDERS

- A. For trucks with air suspension, raise and lower the suspension one final time to confirm that there is adequate clearance between the fenders and wheels.
- B. Repeat the install process for all fenders.
- C. Once fenders are in service, occasionally inspect the 5/8" bolts in the frame to confirm they do not loosen over time.

A DIVISION OF **HIGH BAR BRANDS, LLC**



2701 18th Street SW, Owatonna, MN 55060
1-800-248-3855 | Fax: 507-583-7540
www.highbarbrands.com