

Installation Instructions for Steerable Lift Axle Fender Bracket Kit 10001442



Document #10005681, Revision A

Brackets are Compatible with Models:

Hendrickson SC20 Axle with Welded Brake Cam Tube

(Designed for use with MIN2220 Fenders.)

STEP 1 - IDENTIFY PARTS

- Lay out parts and hardware packs.
- Compare the parts and hardware with bracket kit 10001442 as shown in **Figure 1**.

FIGURE 1

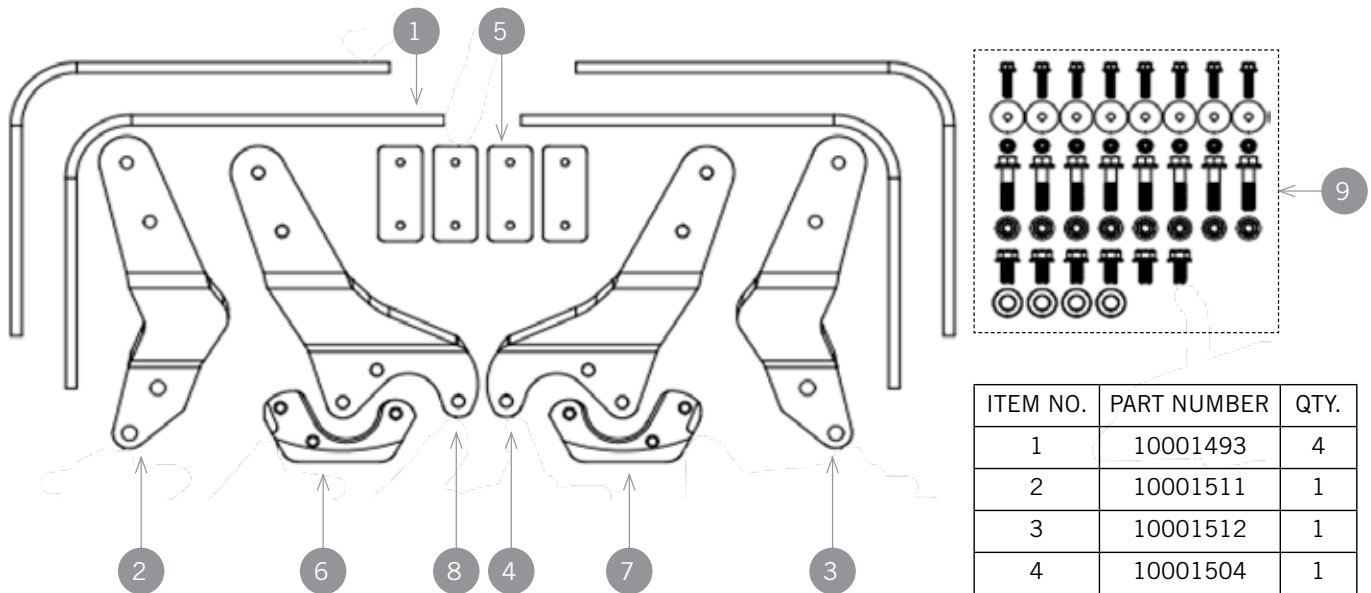

ITEM NO.	PART NUMBER	QTY.
1	10001493	4
2	10001511	1
3	10001512	1
4	10001504	1
5	10001463	4
6	10001505	1
7	10001506	1
8	10001503	1
9	10003060	1

If any of the listed pieces are missing, please call Minimizer at 800-248-3855

STEP 2 - ATTACH BRACKETS TO TRUCK

- Remove the wheel assembly from the hub on the right side of the vehicle.
- Remove the brake drum from the hub.
- Remove the metal dust shield (if equipped) that is attached to the inside of the spindle.
- At the front right corner of the axle, fit the (10001506) bracket around the brake cam tube on the spindle backbone assembly. (**See Figure 2**)
 - The (10001506) bracket has a machined step that fits over the profile of the backbone.
 - Clamp the bracket in place and confirm that the machined step fits flush against the backbone.

FIGURE 2



- c. For proper fitment, it may be necessary to slightly grind down the edge of the weld bead around the brake cam tube and backbone on the inboard side of the backbone. **(See Figure 3)**
- E. With the (10001506) bracket clamped in position, tack weld the bracket to the backbone in two places.
 - a. Paint should be ground off in the welded locations also.
- F. Install the brake drum on the wheel hub and confirm that there is no interference between the drum, brake shoe and the (10001506) fender bracket.
- G. Remove the brake shoe mechanism **(See Figures 4 and 5)**
 - a. First, remove the out and inner retainer springs from the brake shoe.
 - b. Support the lower brake shoe assembly and remove the return spring.
 - c. Set the parts aside and remove the upper brake shoe. **(See Figure 6)**

FIGURE 3



FIGURE 4

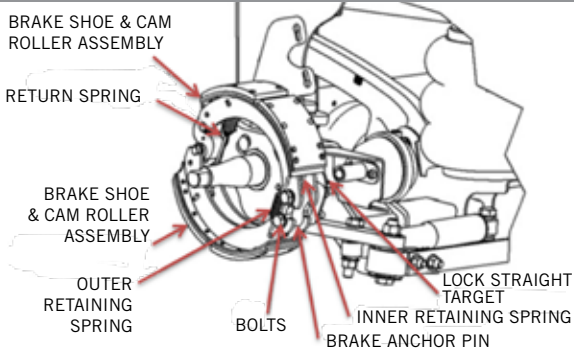

FIGURE 5

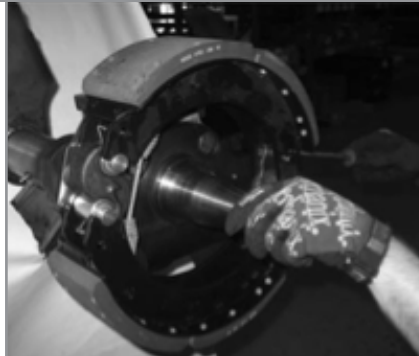

FIGURE 6



FIGURE 7



FIGURE 8

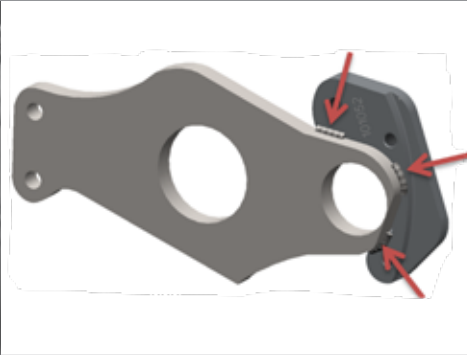

FIGURE 9



- H. Remove the brake anchor pin bolts and discard. **(See Figure 7)**
- I. Three 1/4" fillet welds at 3/4" long each are required to attach the (10001506) bracket to the backbone on the outboard side. **(See Figure 8)**
 - a. Weld with an E7018 electrode or E70XX flux core wire.
 - b. Grind off any paint in the weld areas.
 - c. The camshaft washer may be rotated for ease of welding. Return to original position when finished welding.
- J. Attach the (10001504) fender bracket to the (10001506) bracket. **(See Figure 9)**
 - a. Use three 1/2"-13 x 1" flange bolts provided in the kit.
 - b. **Recommended torque is 80 ft.-lbs.**
- K. Replace the anchor pin bolts with longer bolts. **(See Figure 10)**
 - a. Use 5/8"-11 x 5-1/2" SAE Grade 8 bolts. (Not Included)

FIGURE 10



- L. Install the (10001512) fender bracket over the new 5/8" anchor bolts. **(See Figure 11)**
 - a. Apply new 5/8" locknuts to the new anchor bolts installed in step 2K.
 - b. **Recommended torque is 220 ft.-lbs.**
- M. Re-install the brake shoes, brake drum and wheel assembly. Make sure to torque all wheel lugs and hardware according to the axle manufacturer's specifications.

NOTE:

- Repeat step 2 on the left-side using fender brackets (10001505), (10001503) and (10001511).

STEP 3 - POSITION BRACKETS AND FENDERS

- A. Place the Minimizer fender over the tire using shims for clearance. **(See Figure 12)**
 - a. Place a 1-1/2" block on top of the tire to establish a clearance between the tire and fender. **(See Figure 13)**
- B. Measure the distance from the floor to the bottom edge of the fender on both ends and adjust the position of the fender until both distances are equal.
 - a. The aluminum arms may need to be adjusted inward or outward, so they make even contact with the fender.

FIGURE 11

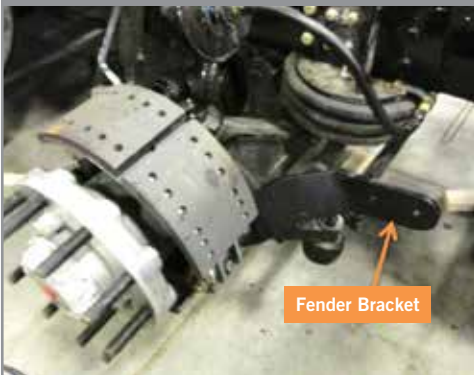

FIGURE 12



FIGURE 13



- C. Clamp the (10001493) aluminum arms to the fender brackets per the steps listed below:
 - a. Align the (10001493) aluminum arms to the inside face of the fender and to the outside face of the fender brackets. **(See Figure 14)**
 - b. The inside end of the arm should point directly toward the center of the spindle.
 - c. Clamp the aluminum arm to the surface of the steel fender bracket with a vice grip clamp.
 - d. The aluminum arms may be longer than needed.
 - i. If necessary, trim any excess material from the aluminum arms that extends past the bend in the mounting plate. **(See Figure 15)**
- D. Use the holes in the steel bracket attached to the axle as a template to locate and mark the mounting holes in the aluminum arms. **(See Figure 16)**
- E. Drill two 9/16" holes in each aluminum arm in the locations that were marked in the previous step.

FIGURE 14



FIGURE 15

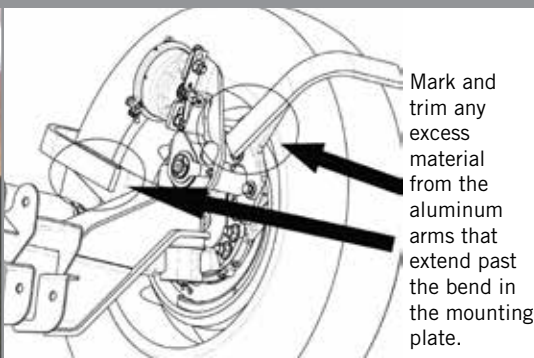
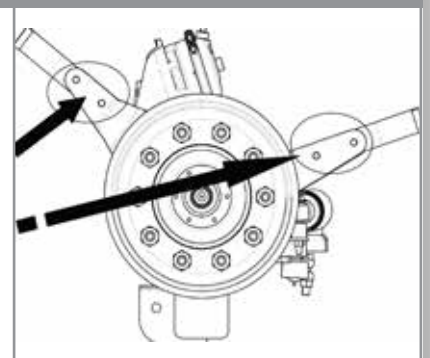

FIGURE 16



- F. Bolt the aluminum arms to the steel fender brackets using the 1/2" x 2" flange head bolts and the 1/2" top lock flange nuts provided in the kit. (See Figure 17)
 - a. **Recommended torque is 75-83 ft.-lbs.**

STEP 4 - ATTACH FENDER TO BRACKETS

- A. Attach the (10001493) aluminum arms and (10001463) steel backing plates to the fender. (See Figure 18)

NOTE:

- **The (10001463) steel backing plate and the (10001493) aluminum arm MUST be installed on opposing faces of the fender to be eligible for Minimizer warranty.**
- B. Confirm that the fender is parallel to the tire.
- C. Align the (10001463) steel backing plate so it is even (top to bottom) with the (10001493) aluminum arm. Use one plate per aluminum arm.
- D. Drill two clearance holes or tap threads in the aluminum arms.
 - a. Option 1 is to drill two 11/32" diameter holes thru the fender and aluminum arm using the steel backing plate as a template.
 - i. Use two 5/16"-18 bolts with self-locking nuts provided in the kit.
 - b. Option 2 is to drill and tap 5/16"-18 threads into the aluminum arm using the steel backing plate as a template. This option provides increased tire clearance.
 - i. Shorter 5/16" bolts are required for option 2 and are not included in the kit.
- F. Install the fender bolts. Recommended torque is 5-7 ft.-lbs.
 - a. **DO NOT EXCEED THE RECOMMENDED TORQUE.**

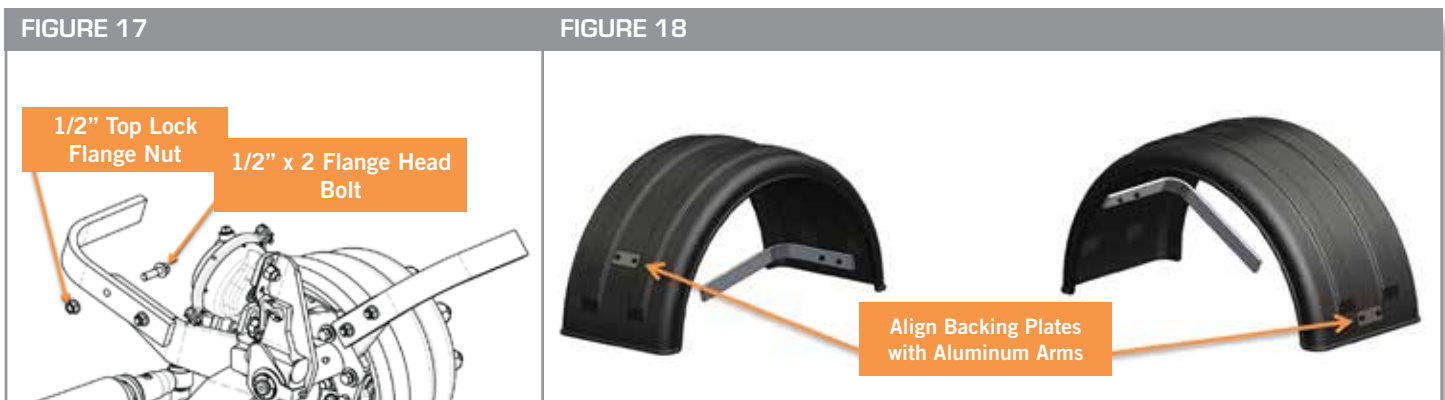

STEP 5 - INSPECT AND REPEAT FOR ALL FENDERS

- A. Repeat steps 2 thru 4 to install the bracket and fender on the opposite side of the vehicle.

A DIVISION OF **HIGH BAR BRANDS, LLC**



2701 18th Street SW, Owatonna, MN 55060
 1-800-248-3855 | Fax: 507-583-7540
www.highbarbrands.com