

## Installation Instructions for Steerable Lift Axle Fender Bracket Kit 10001455



Document #10003185, Revision B

Brackets are Compatible with Models:

Hendrickson Compositolite EXS13 Steerable Lift Axle with Drum Style Brakes.

(Designed for use with MIN161200 & MIN221800 Fenders.)

### STEP 1 - IDENTIFY PARTS

- A. Lay out parts and hardware packs.
- B. Compare the parts and hardware with bracket kit 10001455 as shown in **Figure 1**.

FIGURE 1

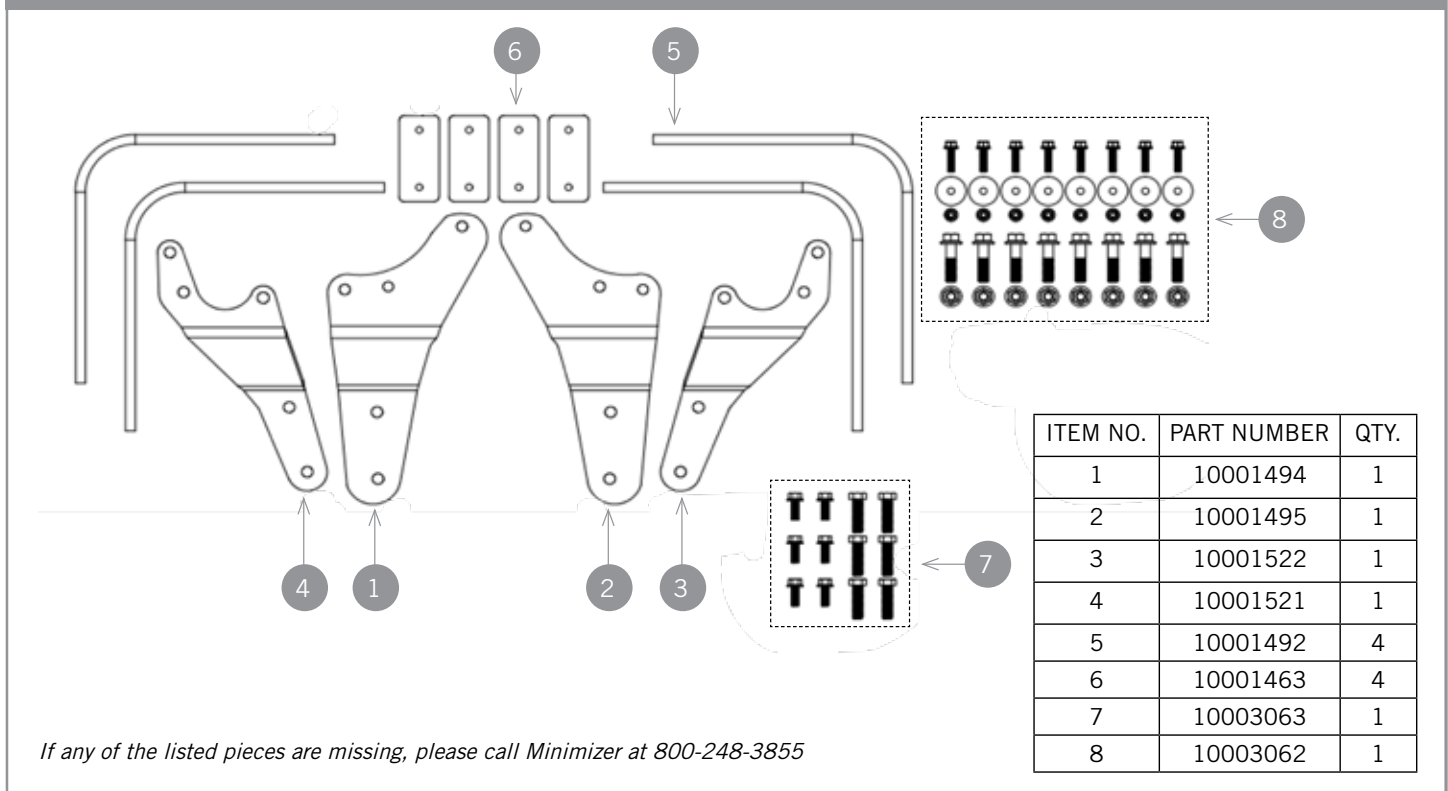

### STEP 2 - ATTACH BRACKETS TO TRUCK

- A. Starting on the right side of the truck, remove the sheet metal dust shield if equipped.
  - a. Dust shields are an optional item and not included on all axles.
- B. The dust shield mounting holes will be utilized to attach the rear fender bracket.
- C. Use three 3/8"-24 x 1" flange head bolts to attach the (10001495) rear fender bracket to the dust shield mount holes. **(See Figure 2)**
  - a. The (10001495) fender bracket should be mounted inward, towards the frame.
  - b. **Recommended torque is 49-54 ft.-lbs.**

FIGURE 2



- D. Remove the three 1/2" bolts, shown in **Figure 3**, from the brake cam tube.
  - a. Do not remove the fourth 1/2" bolt from the cam tube.
- E. Use three 1/2"-13 x 2" bolts provided in the kit along with the existing split washers to attach the (10001522) front fender bracket to the brake cam tube.
  - a. The (10001522) fender bracket should be mounted inward, towards the frame.
  - b. **Recommended torque is 75-83 ft.-lbs.**

**NOTE:**

- Repeat step 2 on the left side using fender brackets (10001494) and (10001521).

**STEP 3 - POSITION BRACKETS AND FENDERS**

- A. Place the Minimizer fender over the tire using shims for clearance. (**See Figure 4**)
  - a. For MIN161200 fenders, place a 3/4" block on top of the tire to establish a clearance between the tire and fender. (**See Figure 5**)
    - i. For MIN221800 and MIN2220 fenders, use a 1-1/2" block to establish clearance.
- B. Measure the distance from the floor to the bottom edge of the fender on both ends and adjust the position of the fender until both distances are equal.
  - a. The aluminum arms may need to be adjusted inward or outward, so they make even contact with the fender.



- C. Clamp the (10001492) aluminum arms to the fender bracket per the steps listed below:
  - a. For MIN161200 fenders, align the (10001492) aluminum arms to the outside face of the fender and to the inside face of the fender brackets. (**See Figure 6**)
    - i. For the MIN221800 fenders, align the aluminum arms to the inside face of the fender and to the outside face of the fender bracket.
  - b. Clamp the aluminum arm to the surface of the steel fender bracket with a vice grip clamp.
  - c. Depending on the fender model used, the aluminum arms may be longer than needed.
    - i. If necessary, trim any excess material from the aluminum arms that extends past the bend in the mounting plate. (**See Figure 7**)

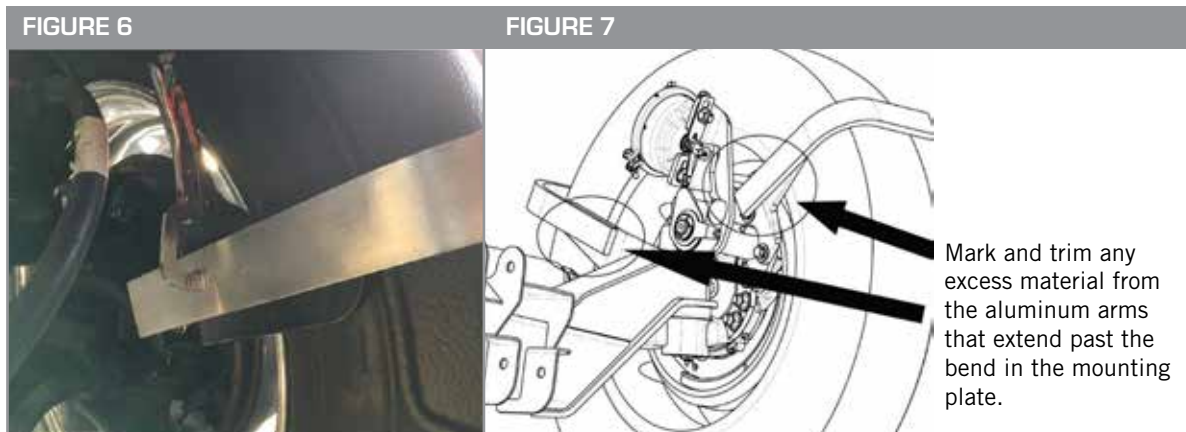

- D. Use the holes in the steel bracket attached to the axle as a template to locate and mark the mounting holes in the aluminum arms. (See Figure 8)
- E. Drill two 9/16" holes in each aluminum arm in the locations that were marked in the previous step.
- F. Bolt the aluminum arms to the steel fender brackets using the 1/2" x 2" flange head bolts and the 1/2" top lock flange nuts. (See Figure 9)
  - a. Recommended torque is 75-83 ft.-lbs.

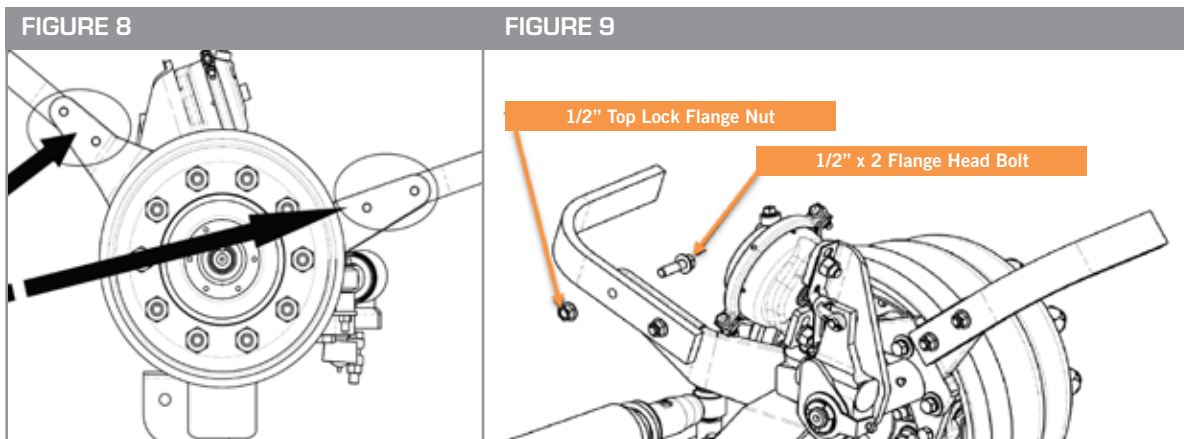

#### STEP 4 - ATTACH FENDER TO BRACKETS

- A. Attach the (10001492) aluminum arms and (10001463) steel backing plates to the fender. (See Figure 10)
- B. The (10001463) steel backing plates are not needed when installing the MIN161200 fenders and may be discarded.

#### NOTE:

- Figure 10 is for reference. The aluminum arm can be mounted on the outside face or inside face depending on the fender used.
- The (10001463) steel backing plate and the (10001492) aluminum arm **MUST** be installed on opposing faces of the fender to be eligible for Minimizer warranty.



- C. Confirm that the fender is parallel to the tire.
- D. Align the (10001463) steel backing plate so it is even (top to bottom) with the (10001492) aluminum arm. Use one plate per aluminum arm.
- E. Drill two clearance holes or tap threads in the aluminum arms.
  - a. Option 1 is to drill two 11/32" diameter holes thru the fender and aluminum arm using the steel backing plate as a template.
    - i. Use two 5/16"-18 bolts with self-locking nuts provided in the kit.
  - b. Option 2 is to drill and tap 5/16"-18 threads into the aluminum arm using the steel backing plate as a template. This option provides increased tire clearance.
  - c. Shorter 5/16" bolts are required for option 2 and are not included in the kit.
- F. Install fender bolts. **Recommended torque is 5-7 ft.-lbs.**
  - a. **DO NOT EXCEED THE RECOMMENDED TORQUE.**

**STEP 5 - INSPECT AND REPEAT FOR ALL FENDERS**

- A. Repeat steps 2 thru 4 to install the bracket and fender on the opposite side of the vehicle.

A DIVISION OF **HIGH BAR BRANDS, LLC**



2701 18th Street SW, Owatonna, MN 55060  
1-800-248-3855 | Fax: 507-583-7540  
[www.highbarbrands.com](http://www.highbarbrands.com)