

Document #10006040

- For cases where a fender mounting bracket is located more than 15" above the bottom edge of a Minimizer fender (as shown in Figure 1) an additional reinforcement may be required on the leading edge of the fender to protect the front fender section from interfering with a tire.
- The amount of clearance between the front inside surface of fender and tire is the second factor that must be considered when deciding whether or not to add reinforcement.
- **If there is less than 3" of clearance between the tire tread and the front inside surface of the fender it is generally a good precaution to add reinforcement to the front of the fender.** In most cases where there is 3" of clearance or more the additional reinforcement is not necessary.

FIGURE 1 - BRACKET POSITION AND CLEARANCE EXAMPLE

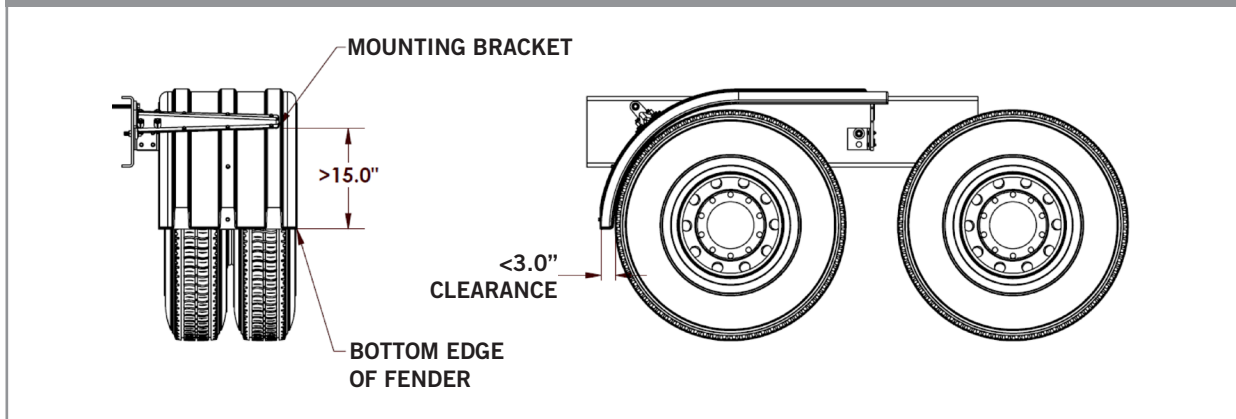

- The above guidelines apply to the following Minimizer fender products: MIN200, MIN300, MIN600, MIN700, MIN900, MIN950, MIN1352/1354, MIN1500/1554, MIN1550, MIN1600, MIN1900, MIN2260, MIN2480, MIIN9900, MIN9950, MINTA910, MINTA900, MINTA1554, MINTF900, MINTF1554.

Recommended Reinforcement Options

- Fabricate a metal reinforcement strip that can be attached to the center rib on the leading edge of the front fender.
- Recommended materials are 1/8" X 2" A36 steel bar or 1/4" X 2" 6061 aluminum bar.
- The metal bar should span from the bottom edge of the fender or the bottom edge of the structural rib (depending on the fender design) and extend up the mounting bracket. See Figure 2 below for an example.
- The two bolts that attach the mounting bracket to the center rib of the fender rib should also attach the metal reinforcement to the fender.

FIGURE 2 - EXAMPLE OF MIN950 WITH METAL REINFORCEMENT

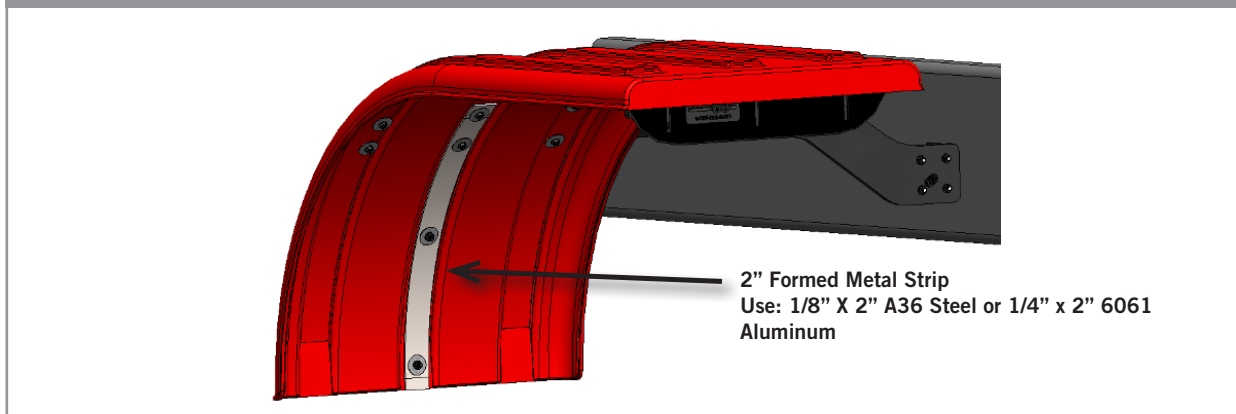

Step by Step Process

1. Determine the length of material needed.
 - a. Measure the distance from the bottom edge of the fender to the top bolt on the mounting bracket.
 - b. Add an additional four inches to the measured dimension for a bend allowance.
2. Cut the metal bar to length. Use the dimension from step 1b.
3. Form the metal bar stock to match the arc of the fender.
4. Fit and clamp the formed reinforcement to the center rib of the fender to confirm that the shape is correct.
5. Drill 5/16" clearance holes in the fender to attach the reinforcement strip to the fender and bracket assembly. Two of the holes should be in the same location as the center mounting bracket bolts. Use a minimum of four bolts per strip. See **Figure 3** below for recommended fastener locations.
6. Mark the hole locations in the metal reinforcement and remove to drill the holes.
7. Attach the metal reinforcement to the fender. Use 5/16" X 1-1/4" bolts, 5/16" lock nuts.
Recommended bolt torque is 10-15 ft-lbs. Flange head hardware is recommended. If flange hardware is not available use fender washers on both the bolt head and nut.

FIGURE 3 - VIEW OF 5/16" FASTENERS (MIN 950)

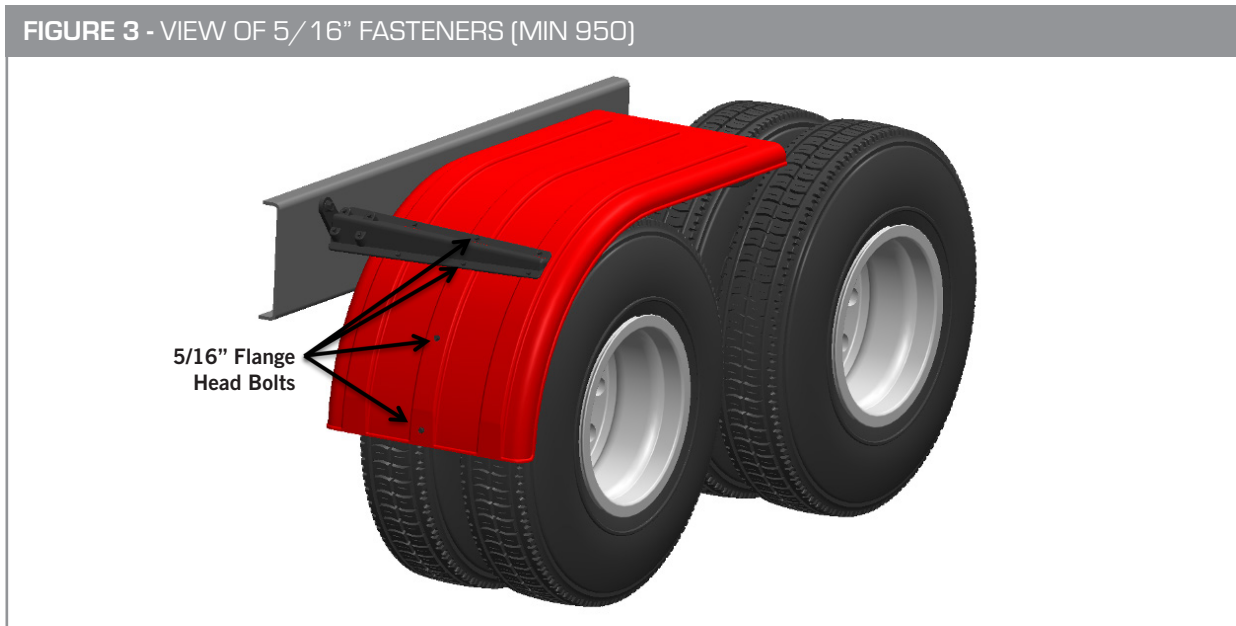

A DIVISION OF **HIGH BAR BRANDS, LLC**



2701 18th Street SW, Owatonna, MN 55060
1-800-248-3855 | Fax: 507-583-7540
www.highbarbrands.com