

# IMPORTANT SAFETY INFORMATION

Item #10006124  
January 2024

## READ BEFORE INSTALLING OR USING MINIMIZER FLOOR MATS

---

FLOOR MAT KITS #10005579, 10005585, 10005591, 10005593, 10006167, 10006169 ARE COMPATIBLE WITH THE FOLLOWING PACCAR FAMILY TRUCK MODELS:

- Kenworth T680 – 2013-2024 with Manual Transmission
- Kenworth T880 – 2014-2024 with Manual Transmission
- Peterbilt 579 – 2013-2024 with Manual Transmission
- Peterbilt 567 – 2014-2024 with Manual Transmission

FLOOR MAT KITS #10005580, 10005586, 10005588, 10005590, 10006164, 10006165 ARE COMPATIBLE WITH THE FOLLOWING PACCAR FAMILY TRUCK MODELS:

- Kenworth T680 – 2013-2024 with Automatic Transmission
- Kenworth T880 – 2014-2024 with Automatic Transmission
- Kenworth W990 – 2019-2024 with Automatic Transmission
- Peterbilt 579 – 2013-2024 with Automatic Transmission
- Peterbilt 567 – 2014-2024 with Automatic Transmission

FLOOR MAT KITS #10005581, 10005587, 10005594, 10005596, 10006166, 10006168 ARE COMPATIBLE WITH THE FOLLOWING PACCAR FAMILY TRUCK MODELS:

- Kenworth W990 – 2019-2024 with Manual Transmission
- 

### SAFETY INSTRUCTIONS FOR INSTALLATION:

- Use only with the specified vehicle make, model and year.
- Do not install on top of other floor mats.
- Install each floor mat with the Minimizer logo facing up.
- Use each floor mat only in its proper location in the vehicle.
- Install and use a retention hooks provided.
- Make sure that the floor mats fit properly in your vehicle floor space.
- Do not place additional floor mats on top of the Minimizer floor mats.
- Carefully follow each of the Installation Instructions for Minimizer Floor Mats on the following pages.

### SAFETY INSTRUCTIONS FOR VEHICLE OPERATION:

- Before starting or operating the vehicle, verify that the Minimizer floor mats are installed correctly, the floor mats are secured by the retention hooks, and that the driver side mat does not interfere with the accelerator, brake, or clutch pedals.
- Make sure there are no loose objects in the vehicle that could possibly interfere with the operation of the accelerator, brake, or clutch pedals.
- If your Minimizer floor mat becomes loose, stop the vehicle at the next safe location. Re-install the floor mat properly and securely. If that is not possible, remove the floor mat and place it in a location where it will not interfere with safe operation of the vehicle.
- Inform all drivers of these warnings before allowing them to operate a vehicle equipped with Minimizer floor mats.

Minimizer floor mats are specifically designed for certain vehicles and may be used safely only with those vehicles. VERIFY THAT THE MAKE, MODEL, AND YEAR OF THE VEHICLE IN WHICH YOU ARE INSTALLING THE FLOOR MATS ARE IDENTIFIED BELOW AS BEING COMPATIBLE WITH THE MINIMIZER FLOOR MATS YOU HAVE SELECTED.

If you have questions about these instructions or proper installation of your Minimizer floor mats, please contact Minimizer at (800) 248-3855

### WARRANTY:

Minimizer Floor Mats are backed by a Lifetime Manufacturer's Warranty and are guaranteed against flaws due to faulty materials and/or unintended production variations. This warranty extends only to the original purchaser and excludes damage caused by abnormal use or conditions, including but not limited to extreme abrasive conditions and/or excessive exposure to chemicals such as bleach, gasoline and other fuels.

Minimizer custom molded floor mats are not Peterbilt and Kenworth goods and PETERBILT and KENWORTH are federally registered marks of PACCAR, Inc.

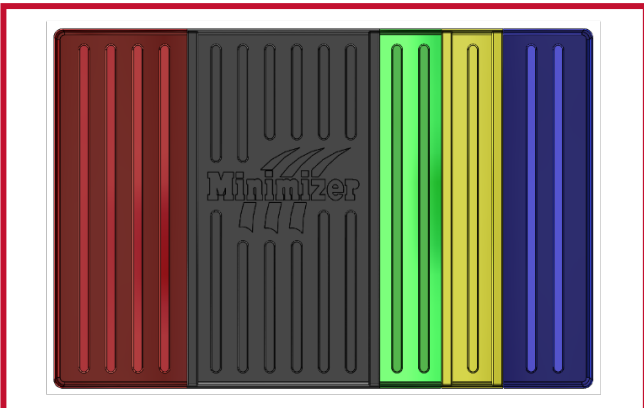
**Installation Instructions:**

1. Remove other floor mats from the vehicle before installing Minimizer floor mats.
2. Install the Minimizer floor mats right side up, with the Minimizer logo visible.
3. Each Minimizer floor mat is contoured to fit a particular location in the vehicle and may be used safely only in that location.
4. The Minimizer floor mat package contains one driver mat, one passenger mat, and one center mat.
5. Test fit the center mat between the seats of the truck. If the truck is equipped with a factory thermos holder as shown in Figure 1, trimming will be required. If no thermos holder is present, install the center mat so the logo reads from left to right when facing forward in the cab. If the truck is equipped with a thermos holder, follow the trimming guidelines below and refer to Figure 2 for a diagram of areas to trim. Use a sharp utility knife to trim the center mat.

**Figure 1 - Thermos Holder**

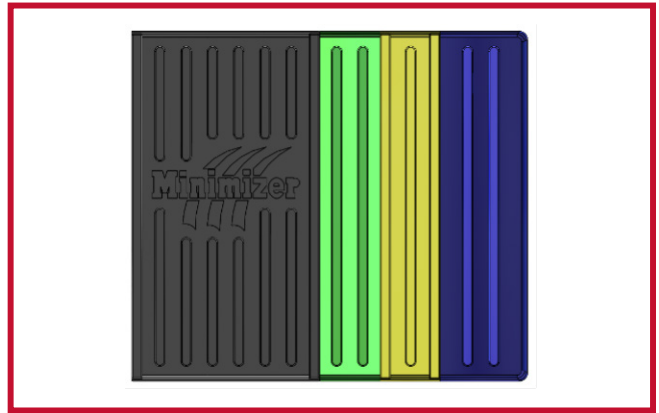


**Figure 2 - Center Mat Trimming Diagram**



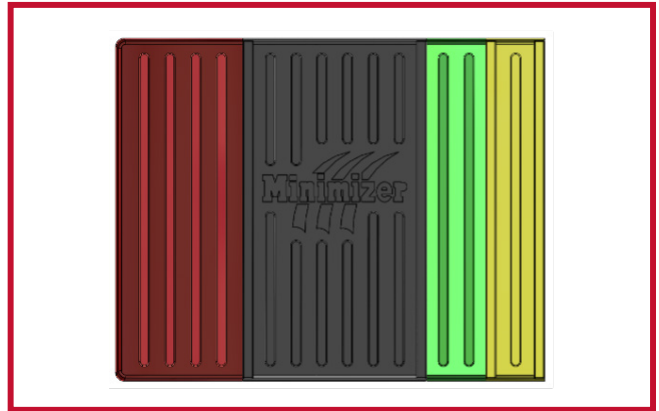
- For day cab trucks that have a fire extinguisher mounted in between the driver seat and passenger seat, trim away the red portion of the center mat preserving the tall rib on the grey side for liquid containment. See Figure 3 for example.

**Figure 3 - Trimming Example**



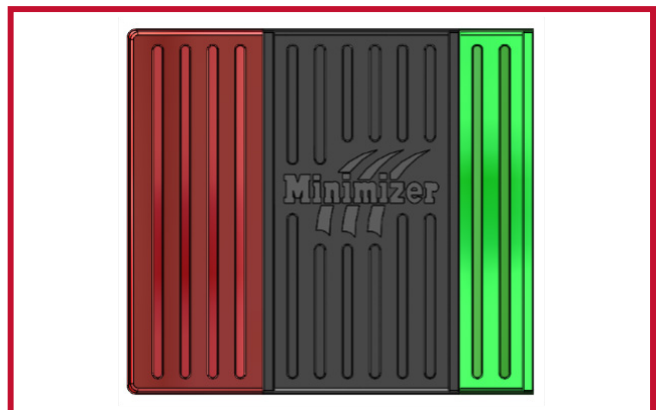
- For trucks equipped with a tube steel static passenger seat or storage box static passenger seat, trim away the blue portion of the center mat preserving the tall rib on the yellow side for liquid containment. See Figure 4 for example.

**Figure 4 - Trimming Example**



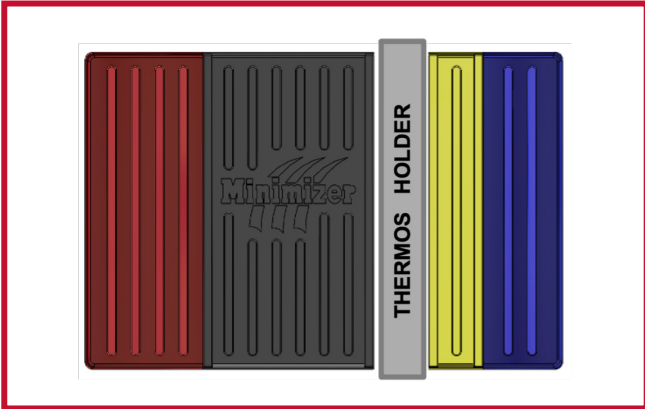
- For trucks equipped with a battery box passenger seat, trim away the yellow and blue portion of the center mat preserving the tall rib on the green side for liquid containment. See Figure 5 for example.

**Figure 5 - Trimming Example**



- Fall all trucks equipped with a factory thermos holder in between the seats, trim away the green, yellow, and blue portions of the center mat preserving the tall rib on the grey side for liquid containment. NOTE: Once the green, yellow, and blue portion of the center mat has been separated from the grey and red portion of the center mat, you may trim away the green portion of the mat preserving the tall rib on the yellow side. The blue and yellow portion can then be used as a narrow mat between the thermos holder and air-ride passenger seat. See Figure 6 for example.

Figure 6 - Trimming Example



6. Test fit the passenger side floor mat. Different seat options may require trimming the floor mat. See Figures 7 and 8 for trimming diagrams. Trim away the yellow portion of the passenger mat preserving the tall rib on the grey side for liquid containment.

Figure 7 - Trimming Diagram for Battery Box Seat

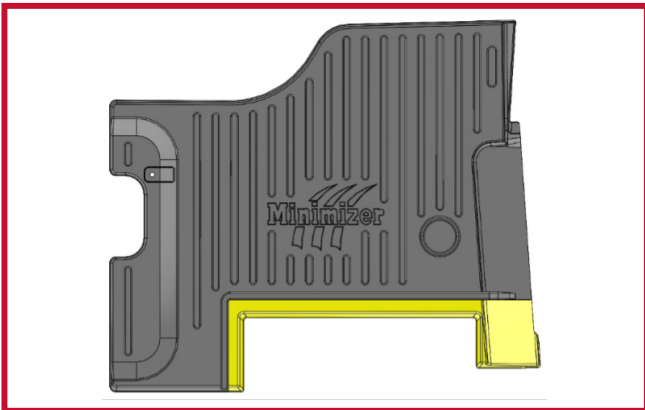
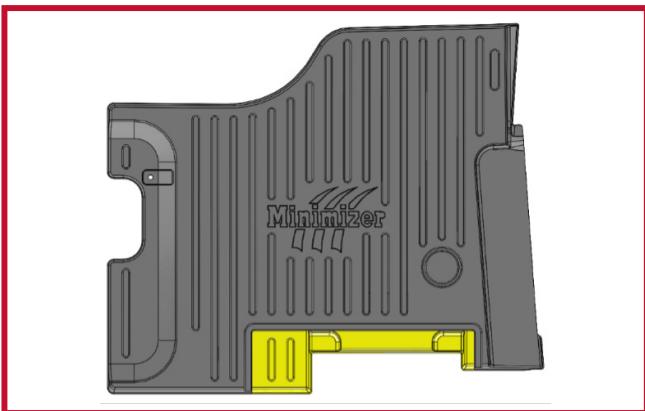


Figure 8 - Trimming Diagram for Tube Steel Static Seat



7. Install the driver and passenger floor mats with the retention hooks provided to secure them from any movement. See below for specific retention hook installation steps.

Retention Hook Installation for Manual Transmissions:

- a. Use a #3 Phillips screwdriver to remove two of the mounting screw from the molded plastic transmission cover that is mounted to the floor. Refer to Figure 9 for mounting screw identification.
- b. Locate the retention hooks provided in the floor mat kit. Insert the mounting screw through the hole in the retention hook and replace the screw in the transmission cover. Tighten the screws using the #3 Phillips screwdriver. Orient the hooks so the tips face inward towards the shifter. Figure 10 below shows proper hook orientation for the driver side mat.

Figure 9 - Retention Hook Location



Figure 10 - Retention Hook Installation



- c. Finish installing the floor mats and engage them onto the retention hooks. The driver and passenger mats must be pushed all the way forward so the front lip makes full contact with the dashboard kick panels as shown in Figure 11.

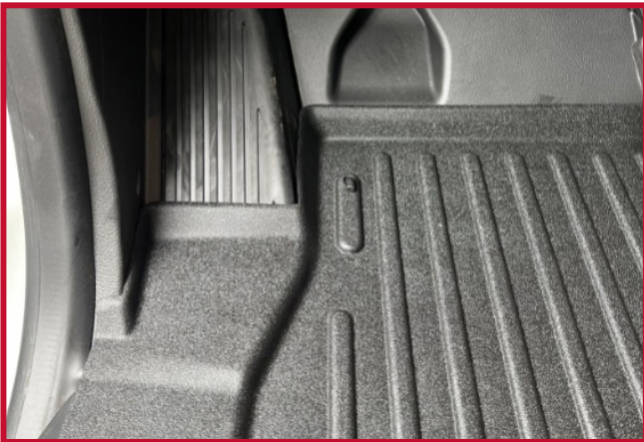
**Figure 11 - Correct Floor Mat Position**



**Retention Hook Installation for Automatic Transmissions:**

- a. Locate the adhesive backed retention hooks provided in the floor mat kit.
- b. Unpack the tube of Primer 94 and read the safety precautions printed on the tube.
- c. Place the floor mat in position and confirm that the mat is pushed forward making full contact with the dashboard kick panels.
- d. The retention hook will be attached to the cab floor in the upper left corner of the driver mat, or the upper right corner of the passenger mat as shown in Figures 12 and 13.

**Figure 12 - Driver Side Retention Hook Location**



**Figure 13 - Passenger Side Retention Hook Location**



- e. Remove the floor mat from the truck.
  - f. Activate the tube of Primer 94 by crushing the tube at the black dot.
  - g. Apply primer to the cab floor in the location where the hook will be adhered.
  - h. Allow the Primer 94 to dry on the truck floor for five minutes.
  - i. With the hook inserted in the floor mat, peel away the paper backing from the hook.
  - j. Re-install the floor mat in the truck.
  - k. Once the floor mat and hook are in position, apply firm pressure to the hook for 30 seconds to ensure a proper bond to the floor.
- 8. FAILURE TO PROPERLY INSTALL THE RETENTION HOOK FOR THE DRIVER SIDE FLOOR MAT MAY ALLOW THE MAT TO SHIFT, WHICH MAY INTERFERE WITH PROPER FUNCTIONING OF THE VEHICLE'S PEDALS, POTENTIALLY RESULTING IN LOSS OF CONTROL OF THE VEHICLE AND SERIOUS INJURY OR DEATH.**
9. Move the accelerator, brake, and clutch pedals through their full range of motion to confirm there is no interference with the Minimizer floor mat.
  10. Prior to operating the vehicle, read the Safety Instructions for Vehicle Operation on the first page.
  11. **FAILURE TO CORRECTLY INSTALL AND USE YOUR MINIMIZER FLOOR MATS ACCORDING TO THE INSTRUCTIONS ABOVE COULD PREVENT PROPER FUNCTIONING OF THE VEHICLE'S PEDALS, POTENTIALLY RESULTING IN LOSS OF CONTROL OF THE VEHICLE AND SERIOUS INJURY OR DEATH.**

A DIVISION OF **HIGH BAR BRANDS, LLC**



**HIGH BAR  
BRANDS**

2701 18th Street SW, Owatonna, MN 55060  
1-800-248-3855 | Fax: 507-583-7540  
[www.highbarbrands.com](http://www.highbarbrands.com)